



Protecting Your Home And Property From Flood Damage

Mitigation Ideas For Reducing Flood Loss

August, 2008



FEMA

Table Of Contents

1	<i>After The Flood: Getting Back To Your Home Safely</i>	1
2	<i>Drying Out Your Home After a Flood: The First Steps</i>	4
3	<i>Cleaning Mold, Mildew and Bacteria</i>	6
4	<i>Obtaining a Building Permit</i>	8
5	<i>Selecting a Contractor</i>	9
6	<i>Tips For Repairing a Flood-Damaged House</i>	10
7	<i>Water-Resistant Building Materials</i>	11
8	Mitigation Steps You Can Take	12
	Relocating Your House	13
	Elevating Your House	14
	House Elevation Regulations	15
	Elevating a Structure with Crawlspace Foundation	16
	Elevating a Slab-on-Grade Wood Frame Structure	17
	Elevating a Mobile Home	18
	Elevating an Electrical System	19
	Elevating Electric Baseboard Heaters	20
	Elevating or Relocating the Electric Panel	21
	Elevating or Relocating the Heating Plant	22
	Suspending a Heating System	23
	Elevating a Washer and Dryer	24
	Relocating a Washer and Dryer	25
	Elevating or Relocating a Water Heater	26
	Elevating an Air Conditioning Compressor or Heat Pump	27
	Anchoring a Fuel Tank	28
	Improving Interior Wall Construction	29
	Pumping Out a Flooded Basement	30
	Sump Pumps	31

Installing an Exterior Floodwall	32
Installing an Interior Floodwall	33
Installing an Exterior Foundation Drainage system	34
Installing an Interior Foundation Drainage System	35
Sealing Openings In Walls	36
Installing a Backflow Valve	37
Installing a Floor Drain Plug	38
<hr/>	
9 <i>Landslides and Mudflows</i>	39
<hr/>	
10 <i>The National Flood Insurance Program and Building in the Floodplain</i>	42
<hr/>	
11 <i>Flood Insurance A Good Investment</i>	44

1 After the Flood: Getting Back to Your Home Safely



A building that has been damaged by rising water can be a dangerous place. This will help you know what to look out for and how to protect yourself and your family. It will also tell you what you need to know about cleaning up and making your home safe to live in again.

Watch Out for These Dangers:

Never assume that a water-damaged house is safe. Going into a building that has been flooded, even after the water is gone, can present a wide variety of hazards that can cause injury, illness or even death. Do not allow children in the home after the flood or while it is being cleaned, inspected or repaired.

- ◆ **Electrical hazards** - Do not enter a flooded or wet building if the power is on. If any electrical circuits have gotten wet, get the power turned off at the main breaker or fuse box and leave it off until the electrical wiring or equipment has been inspected and repaired by a licensed electrician and approved by your local building inspector.
- ◆ **Structural damage** - Do not enter a building if the framing or foundation is damaged. Look carefully before you enter. Leave immediately if shifting or unusual noises signal a possible collapse of the building. Contact your local building inspector for a safety inspection.
- ◆ **Hazardous materials** - Dangerous materials that might be found in flooded homes include pesticides, fuel oil, gasoline, chemicals and other substances that might have been brought in or spilled by the flood. Damaged buildings may also contain asbestos and lead-based paint, which can cause health problems during cleanup. Practically any building material that is not obviously solid wood, metal, or glass could contain asbestos. Lead-based paint can be found pre-1978 housing and is still used in commercial and industrial buildings.
- ◆ **Injuries** - Falling objects, broken or damaged building components and slick surfaces can cause injuries, broken bones, and cuts. Lifting heavy objects can cause back and muscle strains (see “Stay safe while you work.”).
- ◆ **Biological hazards** - Bacteria, viruses, molds and mildew can cause illness when you breathe them in or take them into your body through your mouth or through a cut in the skin. Bacteria or viruses may be left indoors by floodwater, while mold and mildew may grow indoors after the floodwater has receded.
 - Bacteria and Viruses - If you accidentally get floodwater or the dirt it leaves behind into your mouth, you might develop gastrointestinal (digestive tract) illness.

- **Mold and Mildew (Fungi)** - Many building materials, furniture, carpet and other items that stay wet for more than 24 hours will grow mold. Mold colonies are the fuzzy or patchy white, green, brown or black growths that you will see on wallboard, wood furniture and cabinets, clothing, wall studs, and almost any other surface. Mold releases tiny particles into the air that can cause allergic illness like hay fever (coughing, sneezing, eye irritation), asthma symptoms, or other respiratory illness that can be serious. Some molds may also produce toxins that could cause other illnesses. We are exposed to mold every day, indoors and out, but mold contamination can be quite severe in a water-damaged building. The risk is greatest for people with allergies or asthma, and for the very old or very young.

Stay Safe While You Work:

- ◆ **Wear a hard hat and safety goggles** when there is a danger of falling materials.
- ◆ **Wear the right gloves** to protect your hands from cuts or exposure to hazardous chemicals.
- ◆ **Wear rubber boots or hard-soled boots**, preferably with steel toes, when working and lifting.
- ◆ **Wear a face mask.** If you enter a flooded building, wear a dust mask or respirator to reduce your exposure to mold. At your hardware or home supply store, look for a mask with “NIOSH” approval and an N-95 rating. Both of these marks should be on the respirator and the container. Read and follow the instructions on the mask package. Remember that the masks are disposable and should be thrown away at the end of the day.
- ◆ **Stay alert.** Accidents happen when people are tired. Take the breaks you need, and drink plenty of fluids (bottled water, juice, soft drinks) to avoid dehydration. Never drink alcohol when you are working in a flooded building.
- ◆ **Protect yourself from bacteria and viruses.** To keep from getting sick, wear rubber gloves while working; do not eat, drink, or smoke in the house; and wash your hands frequently with soap.
- ◆ **Wet down mold.** Before you touch, move, or clean moldy or mildewed materials, wet the mold with a soapy solution from a spray bottle to prevent the mold from getting into the air. Do this even if the material is already wet because the mold probably won’t be wet. Remember that mold can still make you sick even after you have sprayed disinfectants to kill it.
- ◆ **Be careful lifting.** To avoid back injury when lifting or handling heavy loads like furniture or carpet, avoid lifting loads of more than 50 pounds per person.
- ◆ **Get help.** Before you disturb or remove materials that may be hazardous, take precautions to prevent exposure. If there is a noticeable chemical odor and/or a spilled container of a hazardous material in the building, ask your local health department or fire department for help.
- ◆ **Be prepared.** If you get a cut or a puncture wound that is exposed to floodwater or the dirt it leaves behind, see a doctor. Make sure your tetanus immunization is up-to-date before you work on the house. Once immunized, adults should have a routine “booster” every ten years.

Take These Steps:

If a flooded building is to be safely reoccupied, it must be completely dry. Dirt and trash left by the flood must be removed from building materials and furnishings. Moldy or mildewed items must be completely cleaned and disinfected or must be thrown away. Otherwise mold and mildew will return and possibly cause health problems for you and your family later on.

Before Going Back to Live in Your Home, Take the Following Steps:

- ◆ **Get the mess out.** Remove all floodwater, dirt, and debris left behind by the floodwater.
- ◆ **Remove mold and mildew.** Moldy or mildewed building materials should be thoroughly cleaned and dried or removed and replaced. Any materials or furnishings that soaked up water should be removed from the building.
- ◆ **Check out the floors.** Carpet and padding cannot be cleaned well enough to prevent mold and mildew from growing. Throw them away. Take out the flooring and sub-flooring if they cannot be completely cleaned and dried or if they have started to deteriorate. The remaining floor and/or subfloor must be dried out completely and disinfected. Make sure no moisture is trapped in or on the sub-floor. Sub-flooring made of particleboard or plywood should be removed and replaced because it can’t be completely dried and disinfected. Crawl spaces should also be cleaned out and dried.
- ◆ **Dry out walls.** Walls that were wet should be stripped to the studs and the insulation removed. Walls must remain open to allow them to completely dry. Other wall cavities should be inspected for visible mold growth. Any area inside a wall cavity with visible mold growth should be opened, cleaned, decontaminated and dried. The exterior of each building (siding, etc.) will need to be evaluated to see if any or all of the exterior materials should be removed. Plaster, brick and concrete block

walls can probably be cleaned, disinfected and completely dried.

- ◆ **Check heating and AC systems.** If the heating and air-conditioning system or air ducts were flooded, use special care. The inside parts of heating and air-conditioning systems that contacted floodwater are hiding places for mold. If mold grows in the system, mold particles may get into the air and make people sick. The interior components (furnace, air-conditioner cooling coils, and fans) will need to be inspected, cleaned and decontaminated by professionals. Air registers (vents) and diffusers should be removed, cleaned, disinfected and reinstalled. Replace lined air ducts and ductboard that got wet. Unlined ductwork can be taken apart, washed, disinfected, dried, and put back together. Air duct cleaning services are not very effective in cleaning flooded air ducts and are only useful on bare sheet-metal ducts.
- ◆ **Salvage what you can.** Personal property and furnishings that are moist or wet 24 hours after floodwater recedes will have mold growing in or on them. Clothing and linens may be salvaged by washing with chlorine bleach and detergent, or sent to commercial laundries or dry cleaners. Upholstered furniture, mattresses, and furniture made of particleboard or wafer board should be thrown away. Get information on saving valuable papers, books, and photographs from the American Red Cross.
- ◆ **Remove contaminants.** Make sure that any chemical contamination and hazardous materials have been removed from the building. For proper disposal, contact your local waste disposal service.
- ◆ **Make sure that all parts of the building are dry before rebuilding or repairing.** Mold will grow on replacement materials if the studs, subfloor or other building parts are not completely dry. The structure should be tested with a moisture meter before you start replacing the damaged parts of your home.

Clean and Dry the Right Way:

Nonporous materials (materials that don't soak up water) and furnishings and other surfaces should be thoroughly cleaned, disinfected and allowed to dry completely. First, scrub all surfaces with soap and water and rinse well. (Scrubbing removes mold, mold spores, and the dirt that mold and mildew can grow on.) Then, disinfect everything. Liquid chlorine bleach should be used to disinfect and kill any remaining mold and mildew. Follow the instructions on the label and let the bleach solution remain on the surface for at least 15 minutes before rinsing and drying. After cleaning and disinfecting, you must completely dry each item or mold and mildew will return. To speed drying, keep fresh air circulating.



You can get the document from your local health department or on the Internet at www.cdc.gov/niosh/flood.html

For more information about flood cleanup and removing mold, ask your health department or a Red Cross volunteer for a copy of the Red Cross/FEMA 234 Document: "Repairing Your Flooded Home," or look on the Internet at www.fema.gov/rebuild/recover/resources.shtm

The most important thing you can do to protect yourself is to use common sense and be aware of safety and health risks. Do not enter a building that is clearly unsafe. If you have questions or need assistance, contact your local health department or building inspections office.

2 Drying Out Your Home After a Flood: The First Steps

Floodwaters Affect a House in 3 Ways:

1. The water damages materials. Wallboard will disintegrate if it stays wet too long; wood can swell, warp, or rot; electrical parts can short out, malfunction, and cause fires or shock.
2. Mud, silt, and unknown contaminants in the water not only get everything dirty; they are also unhealthy.
3. Dampness promotes the growth of mildew, a mold or fungus that can grow on everything.

The following steps will help you get started in dealing with these problems. Please do the steps in order.

Lower the Humidity

Everything will dry more quickly and clean more easily if you can reduce the humidity and stop the rot and mildew.

- ◆ **Open up the house.** If the humidity outside is lower than it is indoors, and if the weather permits, open all the doors and windows to exchange the moist indoor air for drier outdoor air. When temperatures drop at night, an open house is warmer and will draw moisture indoors. At night, and at other times when the humidity is higher outdoors, close up the house.
- ◆ **Open closet and cabinet doors.** Remove drawers to let air circulate. Drawers may stick because of swelling. Don't try to force them. Help them dry by opening up the back of the cabinet so air can get into it.
- ◆ **Use fans.** Fans help to move the air and dry out your home. Do not use central air conditioning or the furnace blower if the ducts were under water. They will blow out dirty air that might contain contaminants. Clean or hose out the ducts first.
- ◆ **Run dehumidifiers.** Dehumidifiers help reduce the moisture, especially in closed-up areas.
- ◆ **Use desiccants.** Desiccants are materials that absorb moisture and can be used in drying closets or other closed areas where air cannot move through. Desiccants like those listed below are usually available at hardware, grocery, or drug stores:
 - Chemical dehumidifier packs used for drying boats and damp closets.

- Cat litter made of clay.
- Calcium chloride pellets (used to melt ice in the winter). Hang pellets in a pillow case, nylon stocking, or other porous bag. Put a bucket underneath to catch dripping water. Close the closet or area being dried. Be careful. Calcium chloride can burn your skin. It will also make the air salty, so do not use this product near computers or other delicate equipment.
- ◆ **Call a contractor.** There are contractors who specialize in drying out flooded buildings. Look in the yellow pages under Fire and Water Damage Restoration or under Dehumidifying. Be careful about contractors who inflate prices after a disaster.

Be patient. Drying your house could take several weeks. Until your house is reasonably dry, damage caused by mildew and decay will continue. The musty odor will stay forever if the house is not dried out well.



Sort Contents and Discard Debris

You have 3 types of contents. They should go to 3 different places:

Things You Want to Save

Move things you want to save to a safe, dry place, such as the second story or outside. The longer they sit in water, the more damaged they become. Don't leave wood furniture in the sun because it will warp as it dries.

Things You Don't Want to Save

Put things you don't want to save outside to dry until the adjuster comes to confirm your losses. Take pictures or videotapes and list each item for the record.

Garbage

Get rid of food and anything else that could spoil or go bad immediately. Don't let garbage build up. Garbage piles will cause yet another health hazard by attracting animals and insects. If your insurance adjuster has not come, tell your agent or adjuster that you need to get rid of potential health hazards. That person will tell you how to make sure that your losses are covered. Then throw the stuff out, preferably in sealed plastic garbage bags. Dispose of discarded items properly. Do not burn or bury them. There will usually be more frequent garbage pickups after a flood. Your local newspapers or local TV and radio stations will have announcements about trash pickup schedules and drop-off sites.

Items Soaked by Floodwater	
Should I Throw Them Out?	
Usually	
Mattresses, pillows Foam rubber Large carpets, carpet padding Upholstered couches and chairs Books, paper products	
Always	
Food Cosmetics Medicines and medical supplies Stuffed animals Baby toys	

3 Cleaning Mold, Mildew and Bacteria

Mold, mildew and bacteria are common following floods and other water damage. If unchecked they can lead to sanitation and health problems. The walls, floors, closets, shelves, contents-every flooded part of your house-should be thoroughly washed and disinfected.

In most cases, household cleaning products will do the job if you use them correctly. Check the label on the products to see how much to use. Some products shouldn't be used on certain materials; the label will tell you that. Apply cleaner and give it time to work before you mop or sponge it up. Follow directions and all safety precautions on the container. After cleaning a room or item, go over it again with a disinfectant to kill the germs and smell left by the floodwaters.

Cleaning Tips

Tackle one room at a time. A two-bucket approach is most efficient: use one bucket for rinse water and the other for the cleaner. Rinse out your sponge, mop, or cleaning cloth in the rinse bucket. Wring it as dry as possible and keep it rolled up tightly as you put it in the cleaner bucket. Let it unroll to absorb the cleaner. Using two buckets keeps most of the dirty rinse water out of your cleaning solution. Replace the rinse water frequently.

Walls

Start cleaning a wall at the bottom or where the worst damage was. If you did not have to remove the wallboard or plaster, you may find that the wallboard or plaster won't come clean and you will want to replace it rather than clean it. If you have removed the wallboard or plaster, wash the studs and sills and disinfect them.



Cleaners

1st choice: Non-sudsing household cleaners

2nd choice: Laundry soap or detergent

Disinfectants

1st choice: Commercial disinfectants or sanitizers, such as the quaternary, phenolic, or pine oil based ones. (Check labels for the contents).

2nd choice: 1½ cup of laundry bleach for one gallon of water.

Mildew Removers

1st choice: Commercial mildew removers or mildewicides

2nd choice: Washing soda or tri-sodium phosphate (available at grocery or paint stores). Use five tablespoons per gallon of water.

3rd choice: 1½ cup of laundry bleach for one gallon of water. See below on using bleach.

Bleach

Liquid chlorine bleach, such as Clorox or Purex bleach, can do a variety of flood clean up jobs. Make sure that 5.25% sodium hypochlorite is the only active ingredient. Bleach that has a scent added to improve its smell is available. Scented bleach is fine for cleanup jobs, but don't use it to treat drinking water. Don't use dry bleach or any bleach that does not contain chlorine. Be careful of fumes and wear rubber gloves. Read the safety instructions on the label. Do not mix bleach with other household chemical products, especially ammonia or toilet bowl cleaner; the chemical reaction can create a poisonous gas. Do not use bleach on aluminum or linoleum.

Cleaning Supplies Checklist

- | | |
|--|---|
| <input checked="" type="checkbox"/> Brooms, Mops, | <input checked="" type="checkbox"/> Buckets, |
| <input checked="" type="checkbox"/> Brushes, Sponges | <input checked="" type="checkbox"/> Hose |
| <input checked="" type="checkbox"/> Lubricating Oil | <input checked="" type="checkbox"/> Trash bags |
| <input checked="" type="checkbox"/> Cleaner | <input checked="" type="checkbox"/> Disinfectants |
| <input checked="" type="checkbox"/> Rubber | <input checked="" type="checkbox"/> Hair Dryer |
| <input checked="" type="checkbox"/> Gloves | <input checked="" type="checkbox"/> Rags |

Furniture

Wood alcohol or turpentine applied with a cotton ball may remove white mildew spots on wood. Cream wood restorers and lanolin will help restore good wooden furniture. Upholstered furniture soaks up contaminants from floodwaters and should be cleaned only by a professional. This is also true of carpets and bedding. Unless the piece is an antique or very valuable, upholstered furniture soaked by floodwaters should probably be thrown out.

Clothing and Linens

Even if your washing machine did not get wet, do not use it until you know that the water is safe enough to drink and that your sewer line works. Before you wash clothes in the washing machine, run the machine through one full cycle. Be sure to use hot water and a disinfectant or sanitizer. Take clothes and linens outdoors and shake out dried mud or dirt before you wash them. To prevent a drain clog, hose off muddy items to remove all dirt before you put them in the washer. Check the labels on clothes and linens, and wash them in detergent and warm water if possible. Adding chlorine bleach to the wash cycle will remove most mildew and will sanitize the clothing, but bleach fades some fabrics and damages other fabrics. You can buy other sanitizers, such as pine oil cleaners, at the grocery store to sanitize fabrics that cannot be bleached.

If the label says “Dry Clean Only,” shake out loose dirt and take the item to a professional cleaner. If you want to clean leather yourself, wash the mud off and dry the leather slowly away from heat or sunlight.

Appliances

There is an unexpected danger of shock with some electrical appliances such as TV sets and radios. Certain internal parts store electricity even when the appliance is unplugged. Check the back for a warning label. Appliances with such labels will need professional cleaning.

You will need appliances such as the washing machine, dryer, dishwasher, and vacuum cleaner to help clean your house and its contents. The motors or heating elements can usually be cleaned. If you cannot wait for a professional cleaning job, unplug, disassemble, and hose off the appliances thoroughly (with hot water, if possible). Then clean and disinfect them, but do not use detergents.

Clean and disinfect dishwashers, clothes washers and dryers only with water that has been declared safe for drinking. Make sure the sewer line is working before you start a dishwasher or washing machine. You can speed up the drying process for motors and parts by using a blow dryer or a moisture displacement spray. Moisture displacement sprays, such as electronics parts cleaners or WD-40 lubri-

cating and penetrating oil can also stop rust and corrosion until the appliance can be disassembled and cleaned. One word of caution: The spray is flammable. Read and follow label instructions and precautions.

Moving parts such as motors and pulleys will need oil or grease. Contacts and electrical switches can be cleaned with moisture displacement spray or an aerosol contact cleaner available at electronics or auto parts stores. Allow a motor to run for 30 minutes with no load before using it.

Watch for stripped or damaged insulation around wires. Be sure all appliances are properly grounded. Appliances that must be grounded have a round third prong or a grounding wire on their plug.

Refrigerators, freezers and ovens are more complicated. They may have foam insulation and sealed components that suffered little water damage. But these appliances hold food, and so they should be cleaned, disinfected and checked by a professional or replaced.

Kitchen Items

Throw out soft plastic and porous items that probably absorbed whatever the floodwaters carried in. Floodwaters are contaminated, so you may want to wash dishes by hand in a disinfectant. Air dry the disinfected dishes; do not use a dishtowel. The dishwasher should also be used only after you know your water is safe to drink and your sewer line works. Clean and disinfect it first. Then use a hot setting to wash your pots, pans, dishes, and utensils. (If you have an energy saving setting, do not use it.)

Food

Throw out any food that has been touched by floodwaters. Even food in tin cans should be discarded if the cans got wet during the flood because there is no way to be absolutely certain the food inside is safe. Do not keep food in bottles or jars with bottle caps or screw on lids—they do not keep out floodwaters. For more information on safe food handling, go to www.FoodSafety.gov : Disaster Assistance or call FDA's toll-free information line at 1-888-SAFEFOOD (1-888-723-3366).



For more information: FEMA Publication 606 “Mold and Mildew: Cleaning Up Your Flood Damaged Home”. You can get a printed copy by calling 800.480.2520 or download your own PDF copy from www.fema.gov/library/viewRecord.do?id=3049

4 Obtaining a Building Permit

Local codes generally require a building permit before you repair or floodproof your structure. Usually you need to get a permit for electrical work, plumbing and repairs for structural damage, such as foundations and exterior walls. Because your property may be located in a designated floodplain you will also want to check with the permit department before constructing any floodwalls or berms on your property.

Your permit department will have maps called Flood Insurance Rate Maps (FIRMs) that will show the floodplain in your community. This area is known as the Special Flood Hazard Area (SFHA).

The National Flood Insurance Program (NFIP), and most local and state building codes require that a building in the floodplain that is substantially damaged or substantially improved be treated as new construction. The lowest floor must be elevated at or above the Base Flood Elevation (BFE). The BFE is also known as the 100-year flood level. Substantial damage means that the cost to restore your house to its “before damaged” condition would equal or exceed fifty percent (50%) of the market value of your house before the damage occurred.

Substantial improvement means any reconstruction, rehabilitation, addition, or other improvement of a structure, the cost of which equals or exceeds fifty percent (50%) of the market value of the structure before the start of construction of the improvement. Combining a repair with an improvement where the total cost equals or exceeds fifty percent (50%) of the market value of your house before the damage occurred will also trigger the requirement to elevate.

If your home is substantially damaged you may have no choice but to elevate or relocate your house to meet NFIP standards. Some property owners have chosen the option of relocating their house.

Failure to follow the local building code can result in an order to stop construction, a fine, higher flood insurance rates, denial of flood insurance, or all of the above.



5 Selecting a Contractor

Finding a good contractor to handle difficult repair jobs or to rebuild is essential. Here are some tips to help.

Sleuthing

If you have been satisfied with work done before by a local licensed contractor, use that firm. If you haven't used a contractor before, or if you were unhappy with a previous experience, you may have to do some investigating to increase your chances of getting a good one.

- ☑ Ask the contractor for proof of insurance. This should include a completion bond, disability and worker's compensation insurance. Improperly insured contractors may expose you to liability for accidents occurring on your property.
- ☑ Check on the firm's reputation. Ask the local Better Business Bureau, home builders association or building trades council. They can tell you if the firm has had unanswered complaints filed against it.
- ☑ Ask for references. Reputable contractors are willing to provide names of their previous customers. Contact some of them and ask how satisfied they were with the job and if they would hire that contractor again.

Get It in Writing

No matter how well you know the contractor or how much you trust him/her, get everything related to the job in writing.

- ☑ Get a written estimate. It should include everything you expect the contractor to do. Some contractors charge a fee for an estimate.
- ☑ Obtain a contract. The contract should be complete and clearly state all the work, costs, and payment schedule.

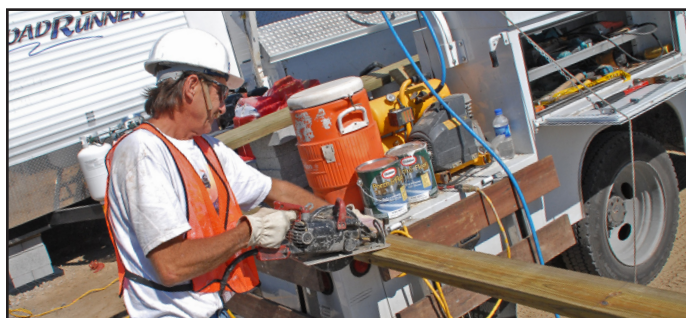

Never sign a blank contract or one with blank spaces. It may be worthwhile to have your attorney look it over if a lot of money is involved.

- ☑ Ask for guarantees. Any guarantees from the contractor should be written into the contract. It should include what is guaranteed, who is responsible for the guarantee *(dealer, contractor, manufacturer) and the length of time for which the guarantee is valid.
- ☑ Get a final contract. A signed contract is binding on both you and the contractor. Don't sign completion papers or make the final payment until the work is finished to your satisfaction and approved by your local building inspector.

Beware of Disreputable Business Activities

Areas recovering from floods are often prime targets for less-than-honest business activities. Here are some points to help safeguard against such practices:

- ◆ Beware of "special deals" offered after a disaster by contractors you don't know.
- ◆ Beware of unknown contractors wanting to use your house as a "model home."
- ◆ Do not sign any contract under pressure by a salesperson. Federal law requires a three day cooling-off period for unsolicited door-to-door sales of more than \$25. If you choose to cancel such a contract within three business days of signing it, send your cancellation by registered mail.
- ◆ Beware if you are asked to pay cash on the spot instead of a check made out to the contracting company. A reasonable down payment is up to 30% of the total project cost.
- ◆ Your contractor should call you or a qualified observer to inspect hidden work (e.g., sewers or basement wall) before it is covered over. Most building departments must inspect electrical and plumbing lines before the walls are covered with wallboard or paneling.

6 Tips for Repairing a Flood-Damaged Building

The most important thing - give your house plenty of time to dry! Rushing to rebuild before everything dries can cause many problems. The rule of thumb is, if it takes a week for visible moisture to disappear, it will take at least another week for unseen parts to dry. Here are some inexpensive measures you can take to make your recovery easier after the next flood.

Utilities

Electrical: Move the main breaker or fuse box and utility meters at least 12" above the Base Flood Elevation (BFE) for your house. (BFE is also referred to as the 100 year flood level). Label each circuit. If the electrical code allows, raise the electrical outlets and switches above the flood level.

Equipment: Relocate or elevate all equipment at least 12" above the BFE. If you plan to replace a flooded furnace, water heater, or air conditioner, install the new one on a higher floor. If your new air conditioner or heat pump will be outside, install it on a raised platform. An updraft furnace in a basement can be replaced with a downdraft furnace on an upper floor. Place heavy appliances on raised platforms. Make sure washers/dryers will not vibrate off the blocks or platform during use. A one or two foot waterproof floodwall around appliances will protect them from shallow flooding.

Walls

Wash and disinfect the studs and sills if the wallboard and insulation were removed. If rebuilding, consider metal studs and sills as they are less damaged by water than wooden ones. Pressure-treated wood resists mildew and wood-eating insects but may swell when soaked. Warning: Some pressure-treated wood should not be used inside the house. It depends on the chemicals used to treat them. Ask your lumber company for consumer information that gives specific precautions.

Wallboard

If you install the wall board horizontally (four feet high), you'll only have to replace half the wall if the next flood is less than 4 feet deep.

Leave the wall open 1 inch above the sill. The baseboards will hide the gap, but all you have to do after the next flood is remove the baseboard and the wall cavity will drain freely and air will circulate better. (Not applicable if local code requires a fire wall.)

Greenboard or other moisture-resistant wallboard may be more sturdy than regular wallboard, but replacement is still often recommended as it presents the same health hazards when soaked with floodwaters.

Floors

Particle board or plywood fall apart when wet for lengthy periods. Floor joists and some wood floors regain their shape when naturally dried. Use screws or screw nails on floors and stairs to minimize warping. Completely dry subflooring before laying new flooring or carpeting. Renail, then sand or place a new underlayment for a new floor.

Paints

Completely dry the surface before painting. This may take several weeks, but paint will peel if applied over a damp surface. Coat concrete surfaces with penetrating sealer for easier future cleanup. Coat water-stained areas with shellac or commercial stain killer first or the stains will bleed through the paint. Dryproofing requires thick plastic or rubberized sheeting. Waterproofing paints do not keep out floodwaters.

Windows and Doors

When appropriate, replace flood damaged windows with vinyl or metal framed windows. Hollow core or polystyrene foam filled metal doors are water resistant. Metal in both windows and doors may rust slightly but that is easily repaired.

7

Water-Resistant Building Materials

Marine plywood	The most water-resistant plywood; it can be used for floor and exterior-wall sheathing.
Exterior-grade plywood	Meant to resist low-level moisture, humidity. Not for water saturation conditions.
Greenboard	Manufacturers do not consider greenboard (moisture-resistant dry wall) to be a flood-proofing material. It can be submerged for several hours without extensive deterioration and it is only slightly more expensive than normal plasterboard.
Rigid (closed-cell) insulation	Will not deform or lose its insulative properties when wet. Can be dried out and reinstalled in wall or floor cavity. Use instead of fiberglass insulation.
Synthetic baseboards	Use instead of wood base.
Galvanized nails	Will not rust after being in floodwaters. Use at all locations up to three feet above the Base Flood Elevation.
Metal doors and frames	Will not warp if saturated. May rust in spots, but this can be sanded out and repainted. Use at all doorways, especially exterior.
Metal and vinyl windows	Will not warp if saturated.
Sheet vinyl flooring or tile	Adheres to marine or pressure treated plywood underlayment with waterproof adhesive.
Indoor and outdoor carpet	Use with synthetic carpet pad. Do not permanently fasten down.
Galvanized drywall screws	Will not rust and allow easy removal and reassembly of interior walls. Use instead of standard drywall nails.
Brick, concrete	Not damaged by water saturation, but must be used in conjunction with a waterproof membrane.
Plastic wood	Made of recycled plastics. Waterproof and dimensionally stable. Check building code for acceptable uses.
Pressure-treated lumber/plywood	Relatively stable in water saturation conditions. Will not sustain heavy damage but may warp. Plywood second only to marine plywood in water-resistance. Use at all flood-levels. Moisture-resistant material below the Base Flood Elevation. (Note: If treated lumber is used, protective gloves must be worn during installation, and a protective barrier such as drywall must be placed between the treated lumber and living space.)

Building Materials to Avoid When Floodproofing

- ◆ Fiberglass or cellulose installation
- ◆ Cork or corkboard
- ◆ Gasoline, motor oil, weed killer, pesticide, lye, drain clear, swimming pool and other chemicals
- ◆ Linoleum
- ◆ Particle board, plywood, chipboard, fiberboard, paperboard, strawboard, Masonite paneling
- ◆ Wallboard, plasterboard, drywall, gypsum
- ◆ Wallpaper

8

Mitigation Steps You Can Take

There is a wide range of flood protection measures for buildings that can eliminate or reduce the risk of future flood damage. Buildings can be relocated out of the floodplain area or elevated above the projected flood levels. There are also a number of relatively inexpensive flood

mitigation techniques that can be used to protect specific elements of a building. This booklet provides illustrations of many flood loss reduction techniques and highlights some important basic building code requirements for building or repairing homes located in a floodplain.

Relocate Elevate Other Options



☑ Relocating Your House

It is possible, and sometimes necessary, to move your house to a new location outside the floodplain. Moving your home out of the floodplain area is the surest way to protect it and yourself from flood damage, but it can be costly. You may need to purchase a new lot unless your present lot is large and has a good building location on higher ground.

To relocate a building, it is detached from the original foundation, placed on a heavy-duty truck bed, transported to the new site and set on a conventional foundation.

Unless there is a hidden structural defect, most homes and small commercial buildings in good structural condition can be moved with no more damage than occasional slight cracks in the plaster or wallboard joints. Single-story frame houses over a crawlspace or basement are easiest to relocate. Multi-story, slab-on-grade, and brick buildings can also be moved.

Moving a house is a complex operation that requires a professional house mover. Before you choose a house mover, obtain bids from several companies and contractors. Before choosing the lowest bid be certain the contractor or mover has the experience and resources to complete the project at the quoted price. Be certain that they have liability insurance to cover the move.

Construction Steps Involved in Building Relocation

- ◆ Locate a new building site.
- ◆ Check the transportation route to the new location. Is it adequate to move the house?
- ◆ On the building site, construct a new perimeter and interior foundation to fit the existing house. Stub in new utilities to as needed.
- ◆ Disconnect, elevate and move the house to the new location.
- ◆ Lower and anchor the building onto the new foundation.
- ◆ Connect the new utilities.



✓ Elevating Your House

Most types of homes, including wood frame, brick veneer, slab-on-grade, crawlspace or homes with basements can be elevated above floodwaters. This is a reliable floodproofing method and requires little human intervention to prepare for a flood. Elevation requirements vary with local codes and ordinances but the new first floor elevation should be at or above the 100-year-flood level. You may wish to exceed the code requirements. Some buildings may be elevated high enough for the new lower level to serve as a garage. All elevated homes need new stairs and porches built to the new height. Elevating a home requires the services of plumbers, electricians, house movers and contractors. Because the new foundation will be in the floodwaters, it is important that it be structurally designed to withstand lateral (sideways) forces like fast-flowing currents and the impact of waterborne debris. A structural engineer can help you design your new foundation and obtain a permit from your building department.

Basic Steps in Elevating a Building:

- ◆ Have appropriate professionals disconnect all utilities.
- ◆ Hire a professional house mover to disconnect your house from the existing foundation, jack it up to the new height and provide a temporary foundation.
- ◆ Have the utilities temporarily reconnected so the house is liveable while foundation work is done.
- ◆ Build a temporary access stair to meet the new height.
- ◆ Build a new, permanent foundation.
- ◆ Have the house mover lower the house onto the new foundation and connect them together with anchor bolts.
- ◆ Have the utilities permanently reconnected.
- ◆ Build a new, permanent access stair and landing

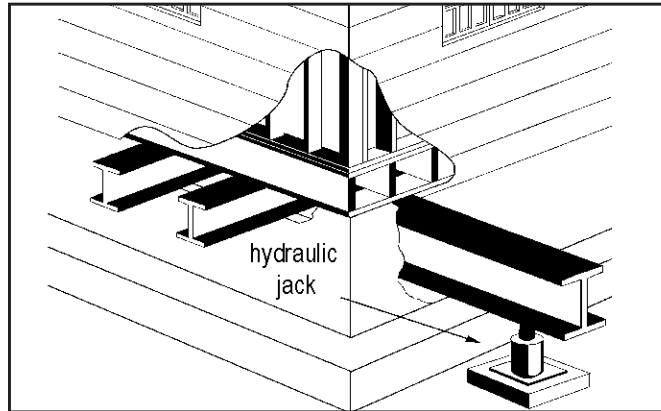

Figure 1: I-beams are placed under lifting points perpendicular to floor joist with a second set beneath for uniform lifting.

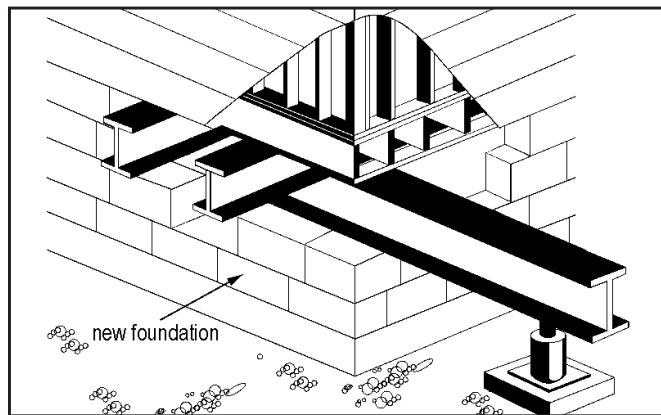

Figure 2: The house is detached from the foundation, lifted by jacks, and a new foundation built beneath it.

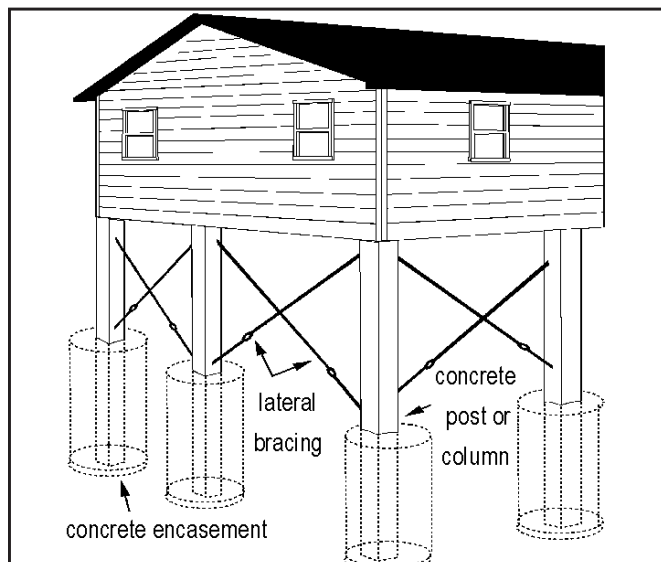

Figure 3: For houses elevated on posts or columns, encase the posts in concrete and provide lateral bracing.

House Elevation Regulations

Substantial Damage

Substantial damage is structure damage from any cause where the cost of restoring the structure to its “before damage” condition would equal or exceed fifty (50) percent of its pre-disaster value.

NFIP Housing Elevation Regulations

Within communities participating in the NFIP, certain requirements apply when building a new home, when substantial damage has occurred to an existing home, or when substantial improvements to an existing home are planned.

- ◆ In A-Zones, the top of a building’s lowest floor, including basement, must be elevated to the Base Flood Elevation (BFE) plus any additional height above the BFE your community may require.

A Zones - Riverine and coastal areas subject to flooding with waves less than 3 ft. in height.

- ◆ In V-Zones, the lowest portion of the horizontal structural members supporting the lowest floor must be elevated to the BFE plus any additional height above the BFE your community may require.

V-Zones - Areas adjacent to the beach subject to unusually high tides with wind driven, velocity waves of three ft. or more.

- ◆ Building materials located below the BFE, must be resistant to flood damage.
- ◆ Any enclosed area below the BFE must be constructed to prevent flotation, collapse, and lateral (sideways) movement of the structure. In A-Zones, exterior walls must have sufficient openings, or be designed, to allow the equalization of the hydrostatic forces on the walls.

For V-Zones only, the walls of the enclosed area must be constructed to breakaway. Solid breakaway walls are not an integral part of the structural support of a building and are intended through their design and construction to collapse under specific lateral loading forces, without causing damage to the elevated portion of the building or supporting foundation. An area so enclosed is not secure against forcible entry.

- ◆ Construction of basements (enclosures with floor levels completely below ground level) is not permitted below the BFE.
- ◆ All machinery and equipment servicing the building must be elevated to or above the BFE or designed to prevent water from entering or accumulating during flooding. Such machinery/equipment includes but is not limited to furnaces, heat pumps, hot water heaters, air-conditioners, washers, dryers, refrigerators and similar appliances, elevator lift machinery, and electrical junction and circuit breaker boxes.
- ◆ All space designed for human habitation, including bedrooms, bathrooms, kitchen, dining, living, family and recreation rooms, must be elevated to or above the BFE.
- ◆ Uses permitted in spaces below the BFE are restricted to vehicular parking, limited storage, and building access (stairs, stairwells and elevator shafts).

Elevating a Structure with Crawlspace Foundation

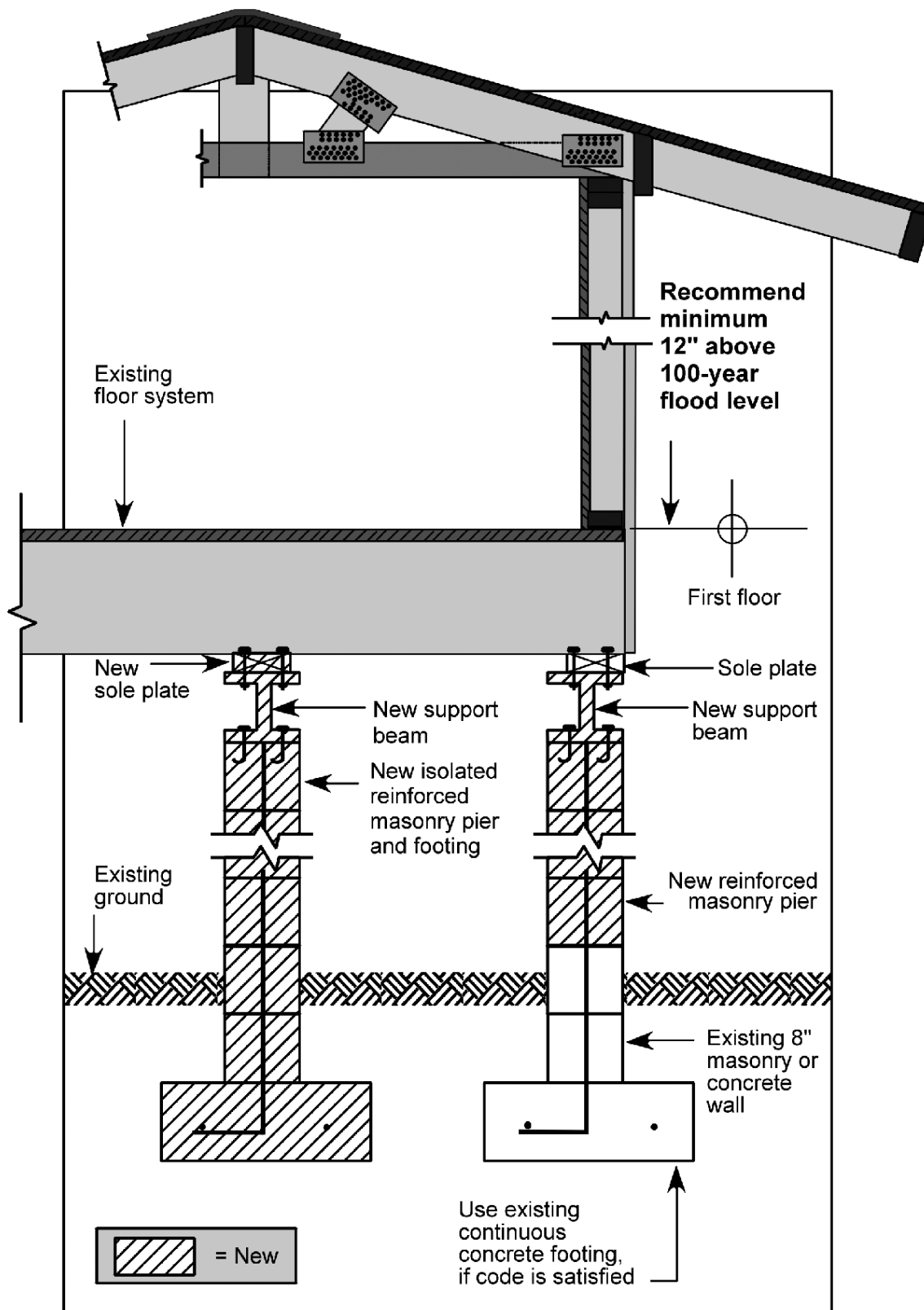

Elevating a Slab-on-Grade Wood Frame Structure

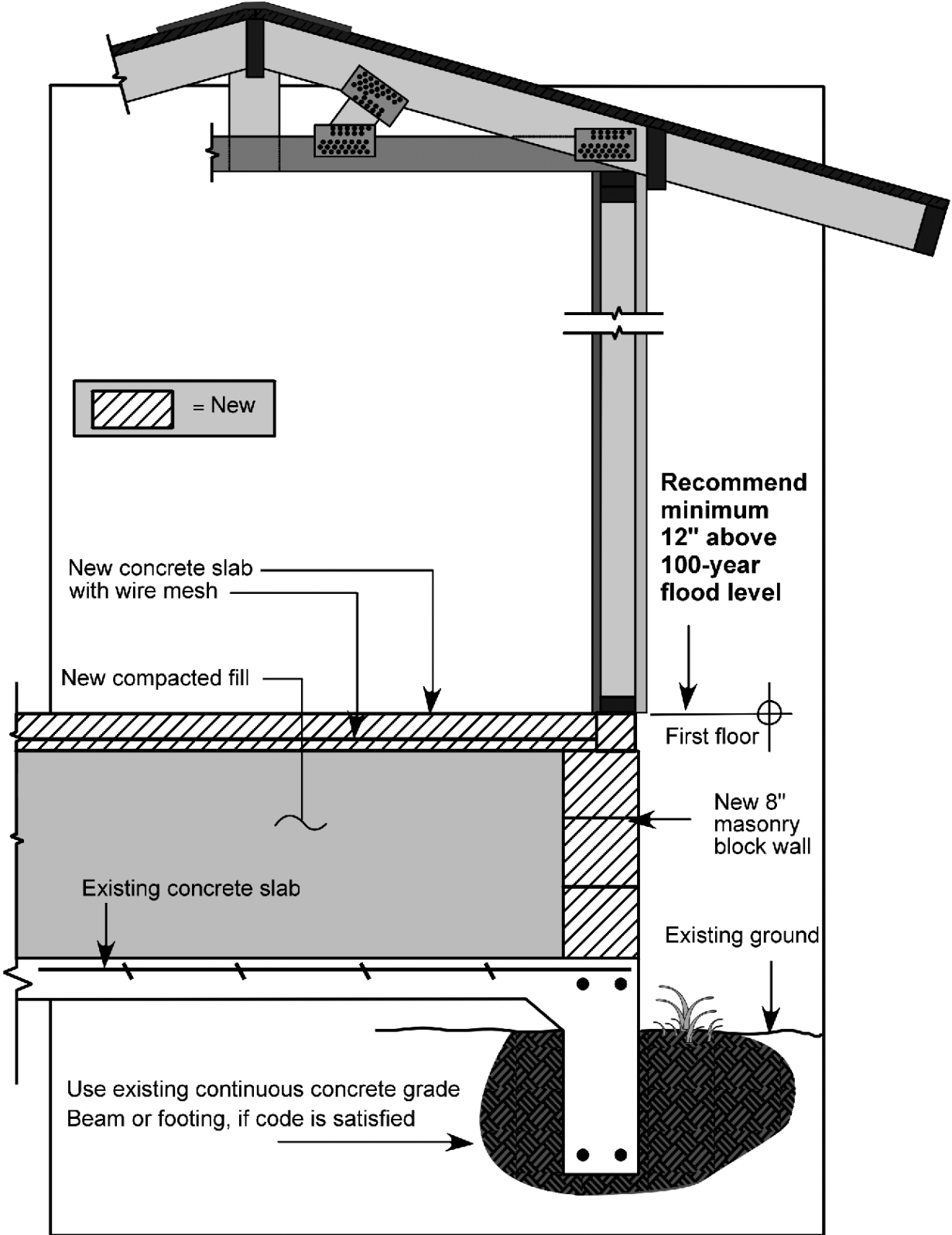

Elevating a Mobile Home



Manufactured Home Showing Cross Bracing and Foundation

Foundations, cross bracing and tiedowns are the three basics of the proper elevation and anchoring of a manufactured home. Each is essential for a safe and secure mobile home installation.

Foundations

A poured concrete footing, reinforced with rebar, gives maximum stability. Extend rebar from the footing and up into the steel reinforce concrete or concrete block pier. Solidly fill each concrete block with concrete. Cast threaded anchor bolts into the top of each pier to anchor the mobile home frame to the foundation. Posts attached to piers with special connectors cast into the concrete are also effective. In areas with soft ground, post foundations may be able to achieve the required foundation strength. Drive posts into the ground down to a rock foundation, or to a depth specified by an engineer. Backfill posts with concrete for maximum strength.

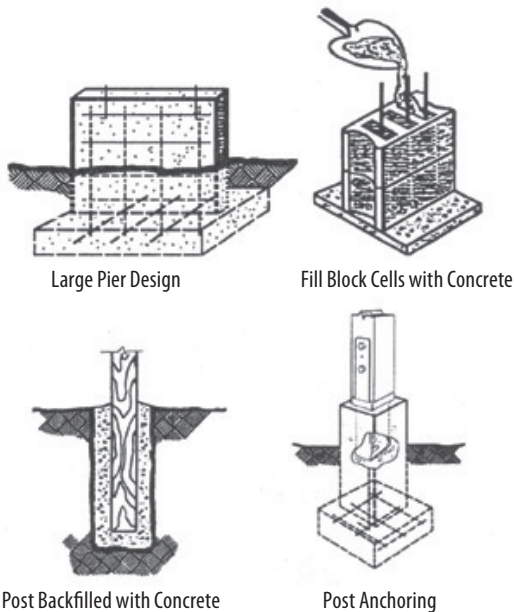

Large Pier Design

Fill Block Cells with Concrete

Post Backfilled with Concrete

Post Anchoring

Note: In order for manufactured/mobile home owners located in Special Flood Hazard Areas to be eligible for NFIP flood insurance, their manufactured/mobile home must be able to resist floatation, collapse or lateral movement either by: 1) Over the top or frame ties to ground anchors; 2) or in accordance with the manufacturer's specifications; 3) or in compliance with the community's flood plain management requirements unless it is a manufactured/mobile home on a permanent foundation continuously insured by the NFIP on the same site since 9/30/82. (Source: NFIP Standard Flood Insurance Policy, Article 6, Paragraph H)



Slab Anchor

This type of anchor is embedded in a cement foundations slab. Straps are then tied from the anchor to the frame of the manufactured homes.

Cross-Bracing

Diagonal bracing reduces foundation twisting and the potential of collapse in flooding or high winds. Brace foundation posts with 2-inch nominal lumber bolted to the piers, or with steel rods fitted through drilled holes, fastened with nuts and tightened with turnbuckles.

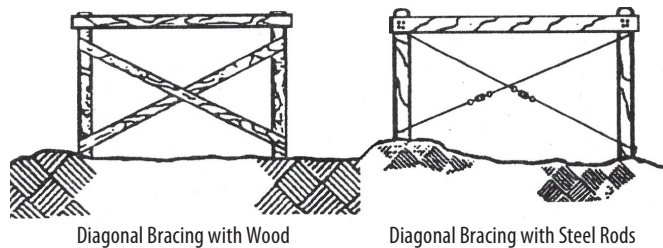

Diagonal Bracing with Wood

Diagonal Bracing with Steel Rods

Tie-Down Straps

Tie-down straps are used at the base of the manufactured home and can be tied over the top. The most common failure is pullout of the ground anchor. For maximum pullout resistance, cast the anchor into a concrete deadman.

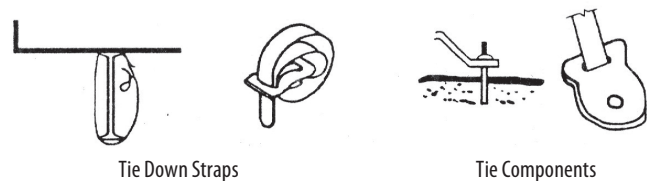

Tie Down Straps

Tie Components

Elevating an Electrical System

The surest way to protect your valuable electrical system is to keep it from getting wet. When rebuilding after a flood, or repairing by wet floodproofing, move all wiring at least one foot above the 100-year flood level. All outlets, switches, light sockets and junction boxes, as well as the main breaker or fuse box and electric motors, should be out of danger of getting wet.

Run wires overhead. If a wire has to run into the areas that could get wet use a wire rated for underground use. No wire should end in the flood zone and all junctions should be in approved junction boxes. If a wire has to terminate below the 100-year flood level it should be specially marked in the panel box and turned off at the time of a flood warning.

Change all outlets to ground fault interrupters (GFI). Be sure all electrical wiring is done by a licensed electrician and approved by the local building department.

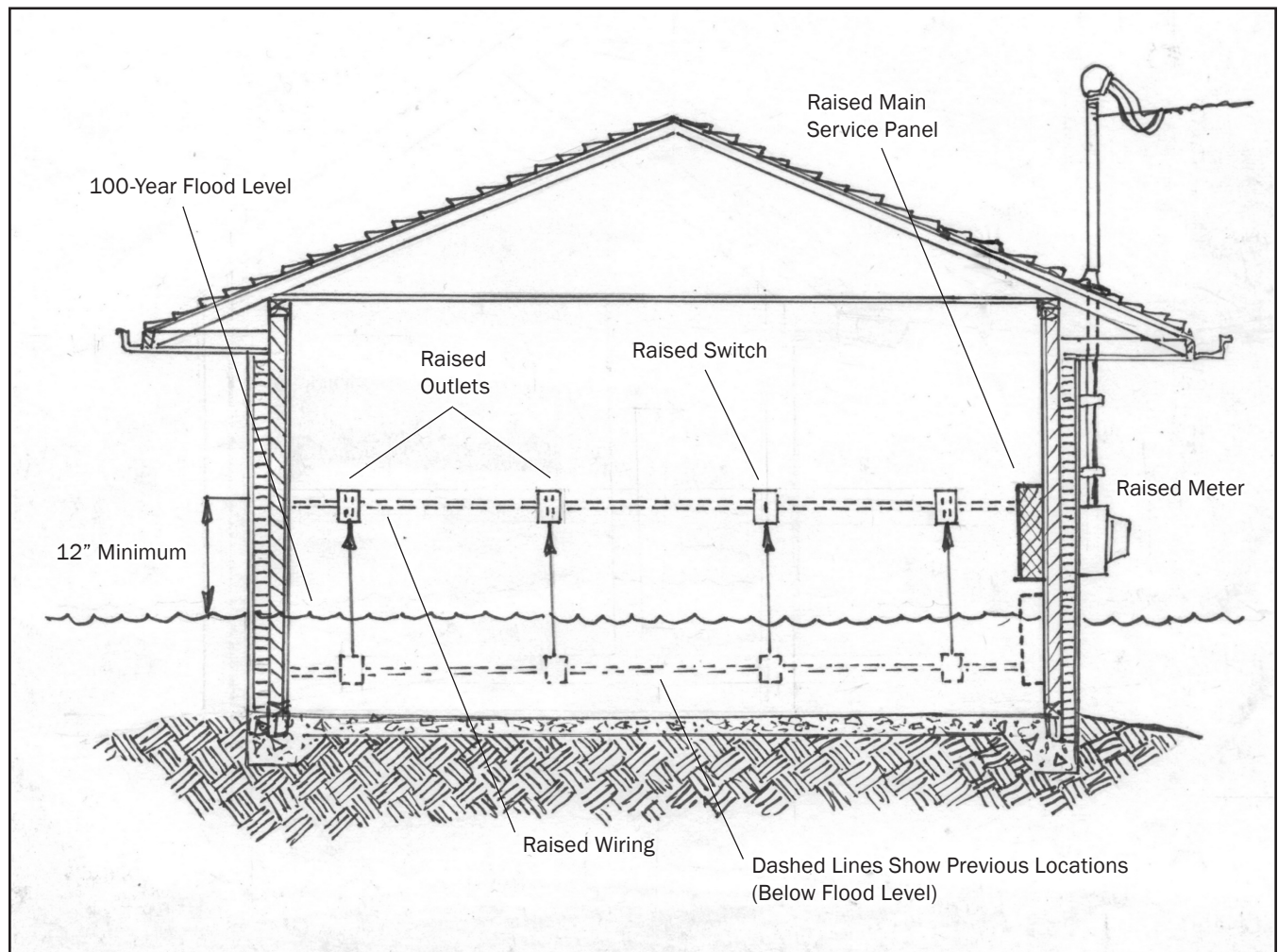

Certain repairs are not permitted for substantially damaged buildings. Check with your local building official or floodplain administrator before beginning repairs.

Elevating Electric Baseboard Heaters

Protect your electric baseboard heater system by elevating it at least one foot above the 100-year flood level. Use waterproof wall construction materials and techniques for the wall area below the baseboard units.

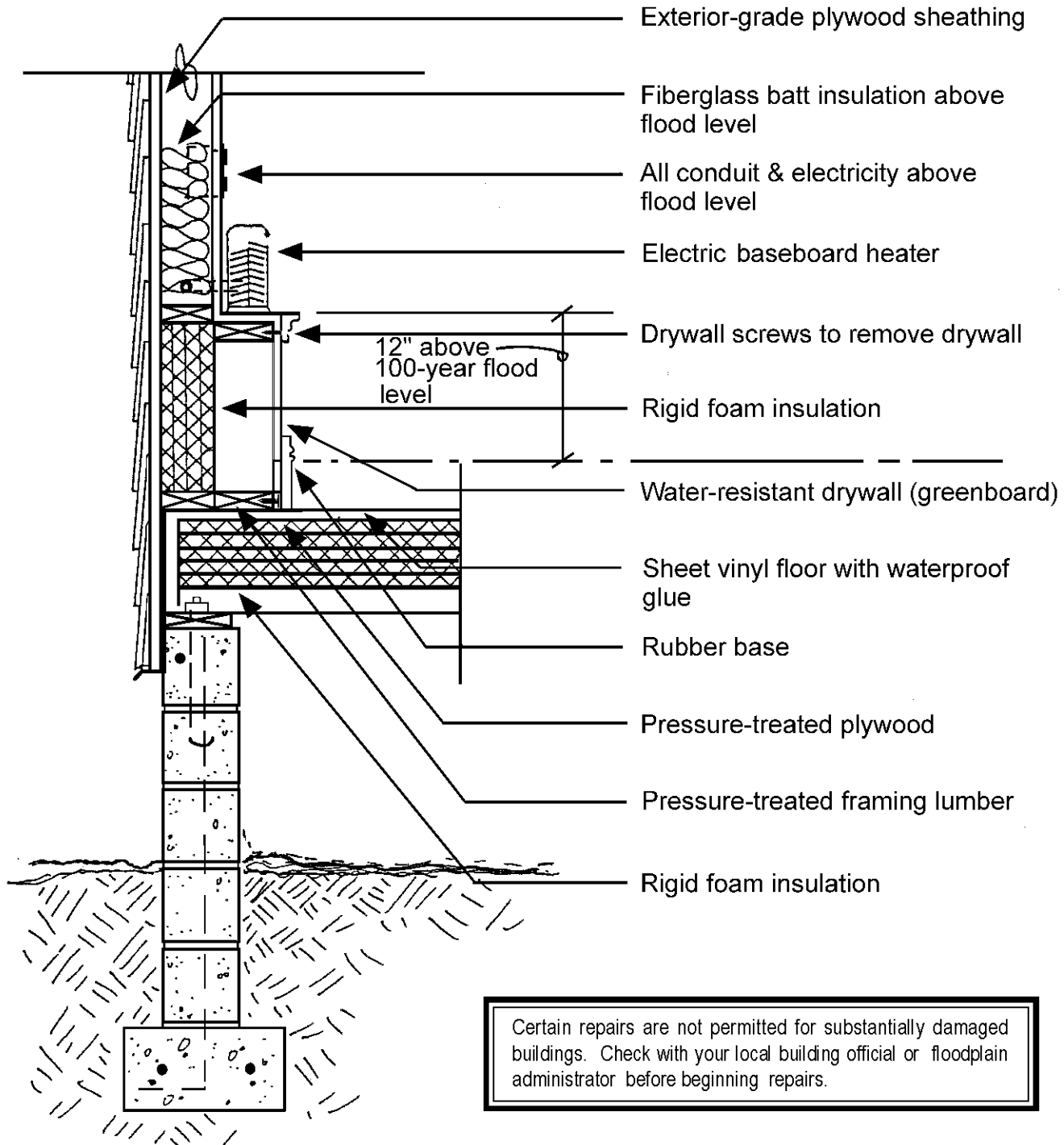

Elevating or Relocating the Electric Panel

Elevate or relocate your electric panel above the 100-year flood level to help prevent damage. All relevant permits must be obtained before work begins, and all work must conform to state and local building codes.

Elevate

Relocate electric panel to a recommended minimum 12" safety margin above the base flood elevation or the highest known flood level if you are outside of any known flood zone. The maximum panel height is regulated by code.

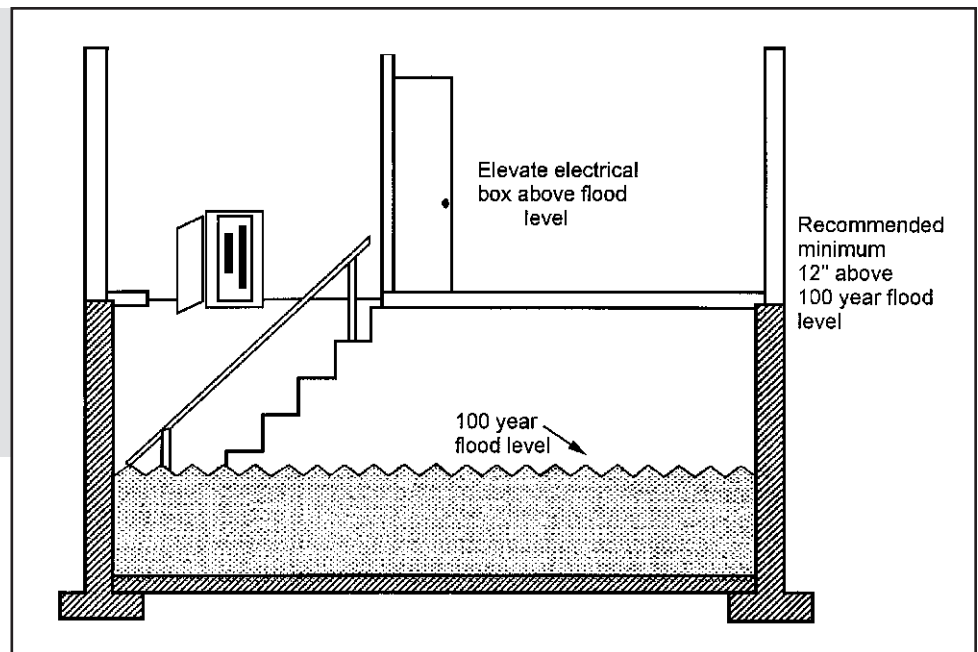

Relocate

Relocate the electric panel to available space above the first floor to protect it from flooding.

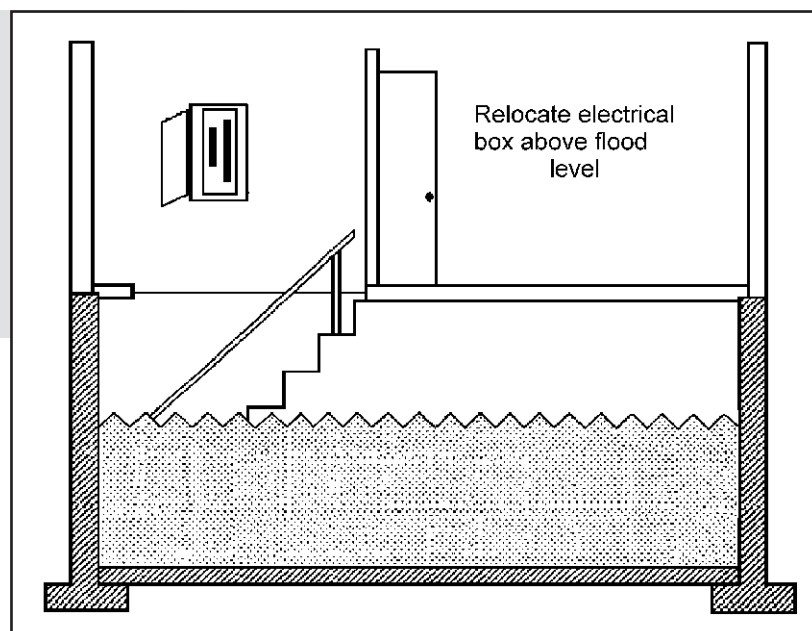

Certain repairs are not permitted for substantially damaged buildings. Check with your local building official or floodplain administrator before beginning repairs.

Elevating or Relocating the Heating Plant

When relocating or raising the heating plant be sure it will have a 12 inch safety margin above the 100-year flood level. If the existing ductwork for your furnace is below the 100-year flood level (e.g. inside a slab or crawlspace beneath the home) it should be relocated so that it distributes heat from at least one foot above the 100-year flood level. Your local building department can help you determine your 100-year flood level. If you locate the furnace on an upper floor or attic it will require the installation of a “downdraft” furnace, which is slightly different from a standard model. If you are replacing your furnace ask your supplier for information on a downdraft system.

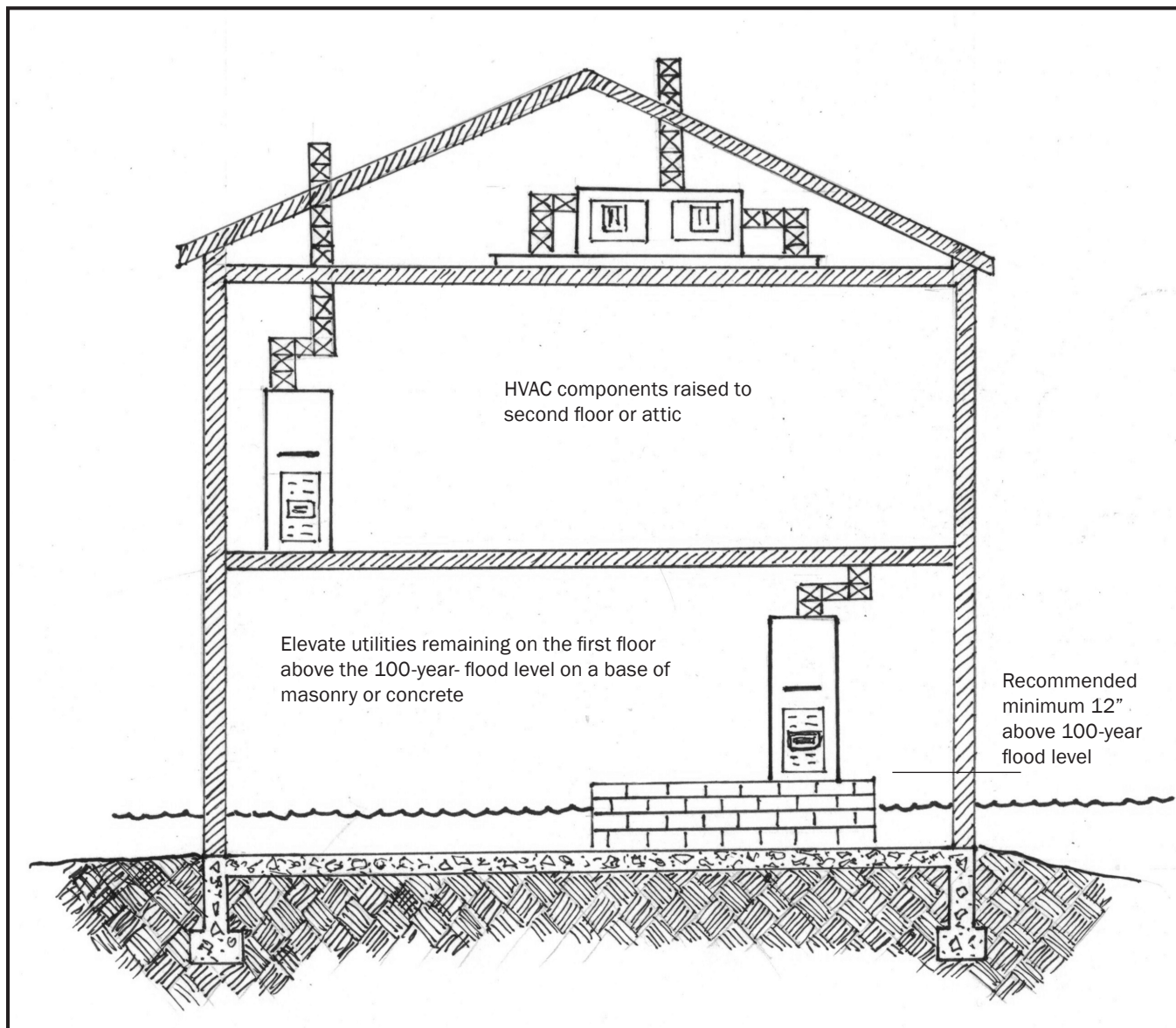

Certain repairs are not permitted for substantially damaged buildings. Check with your local building official or floodplain administrator before beginning repairs.

Suspending a Heating System

Suspend the heating system with a safety margin of at least 12" above the 100-year flood level and in a manner that conforms to the manufacturer's specifications and all applicable state and local building codes.

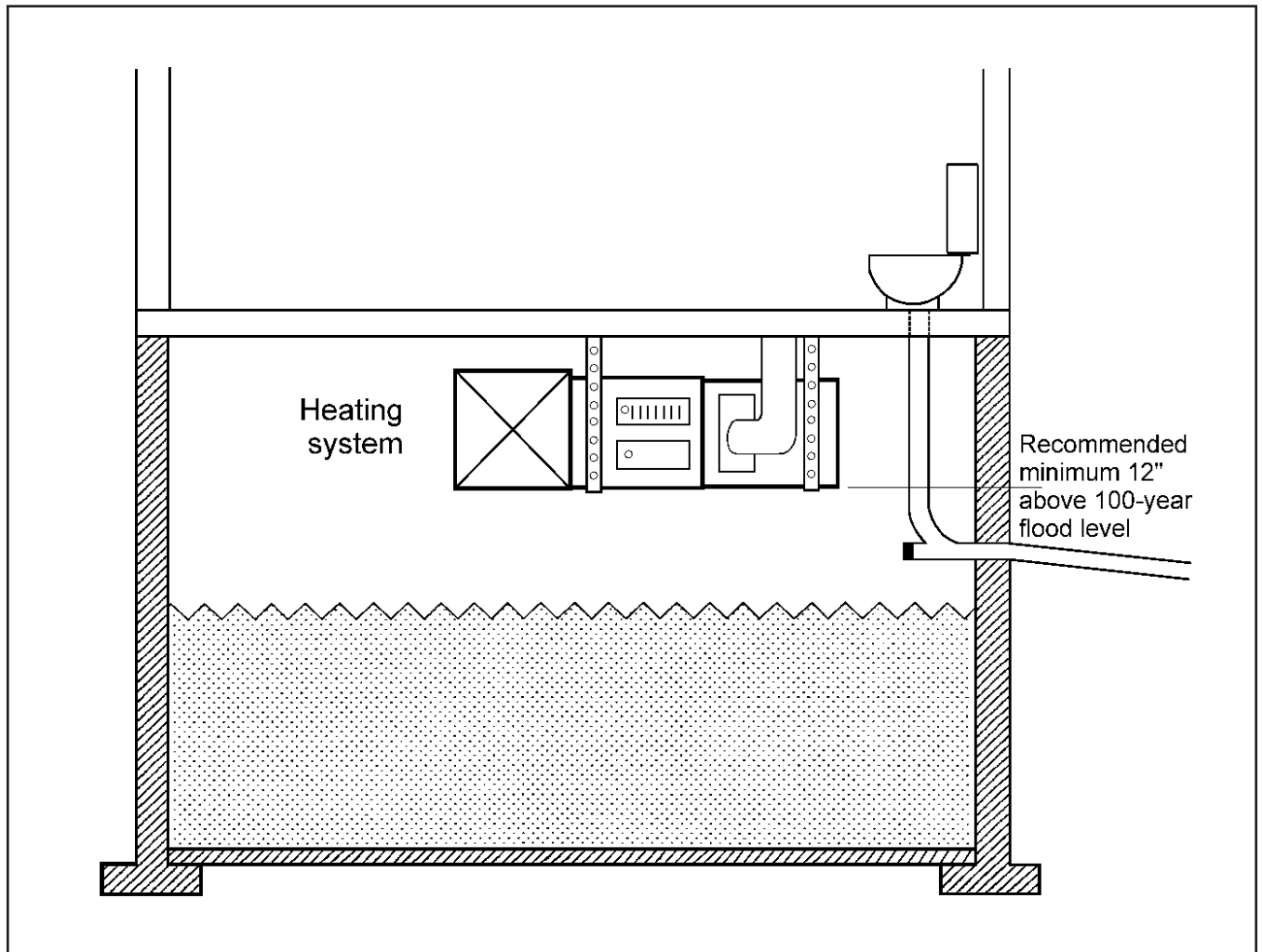

Certain repairs are not permitted for substantially damaged buildings. Check with your local building official or floodplain administrator before beginning repairs.

Elevating a Washer and Dryer

Elevate your washer and dryer on a masonry or pressure treated lumber base to at least a 12" safety margin above the 100-year flood level.

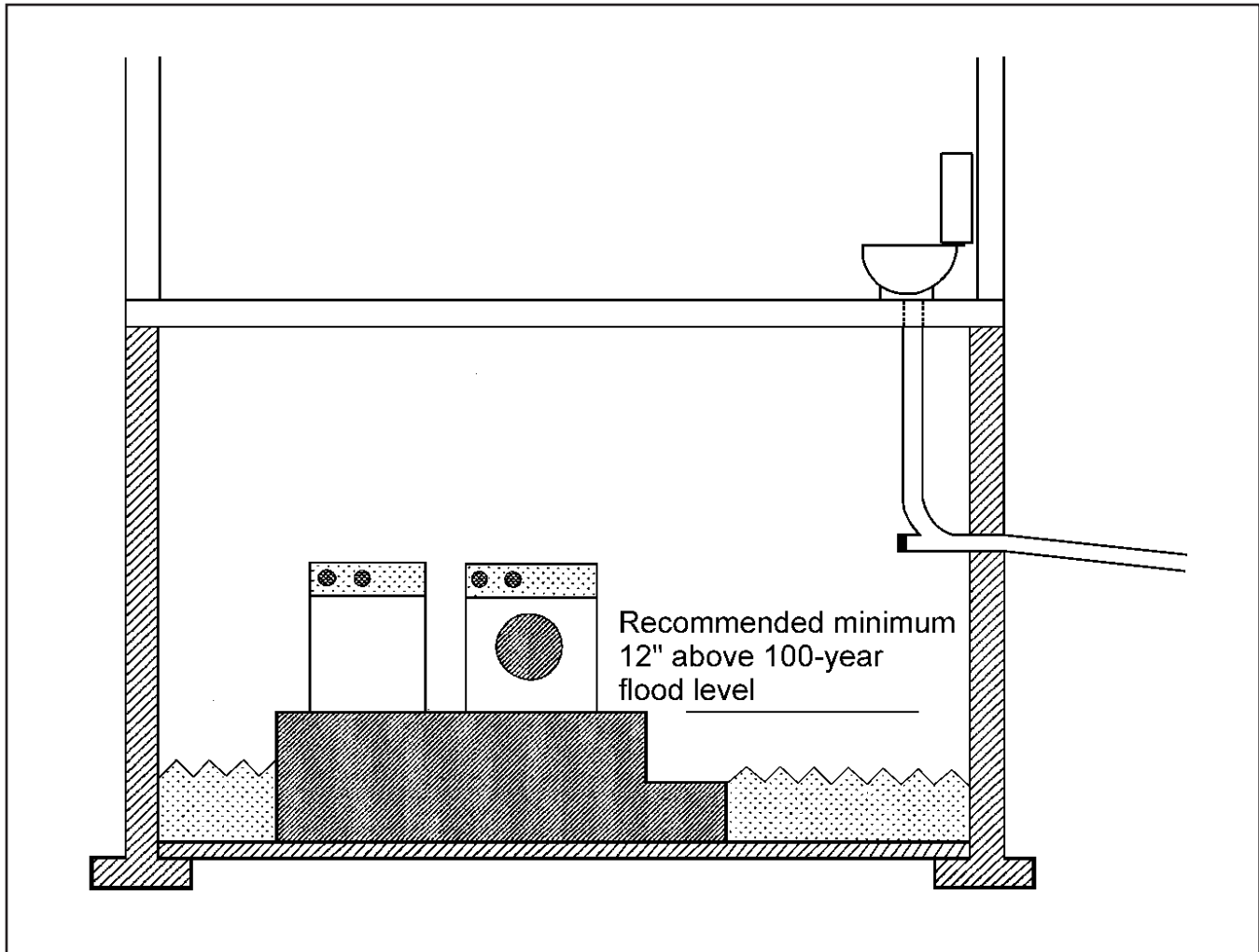

Certain repairs are not permitted for substantially damaged buildings. Check with your local building official or floodplain administrator before beginning repairs.

Relocating a Washer and Dryer

To protect them from flood damage, relocate washer and dryer to a floor at least 12 inches above the base flood elevation.

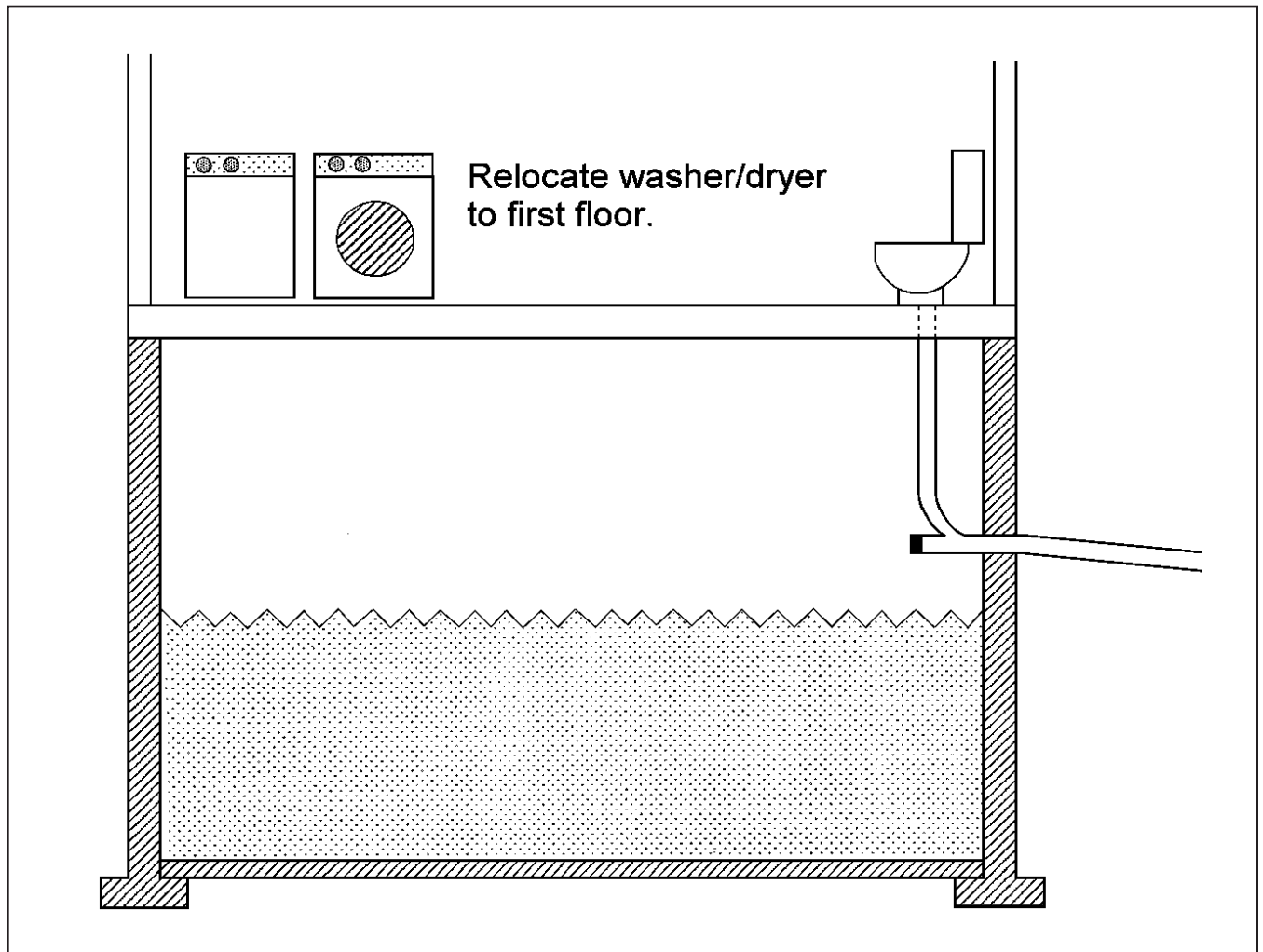

Certain repairs are not permitted for substantially damaged buildings. Check with your local building official or floodplain administrator before beginning repairs.

Elevating or Relocating a Water Heater

When relocating or raising the water heater be sure that it will be at least 12 inches above the 100-year flood level. Consult your local building department for details.

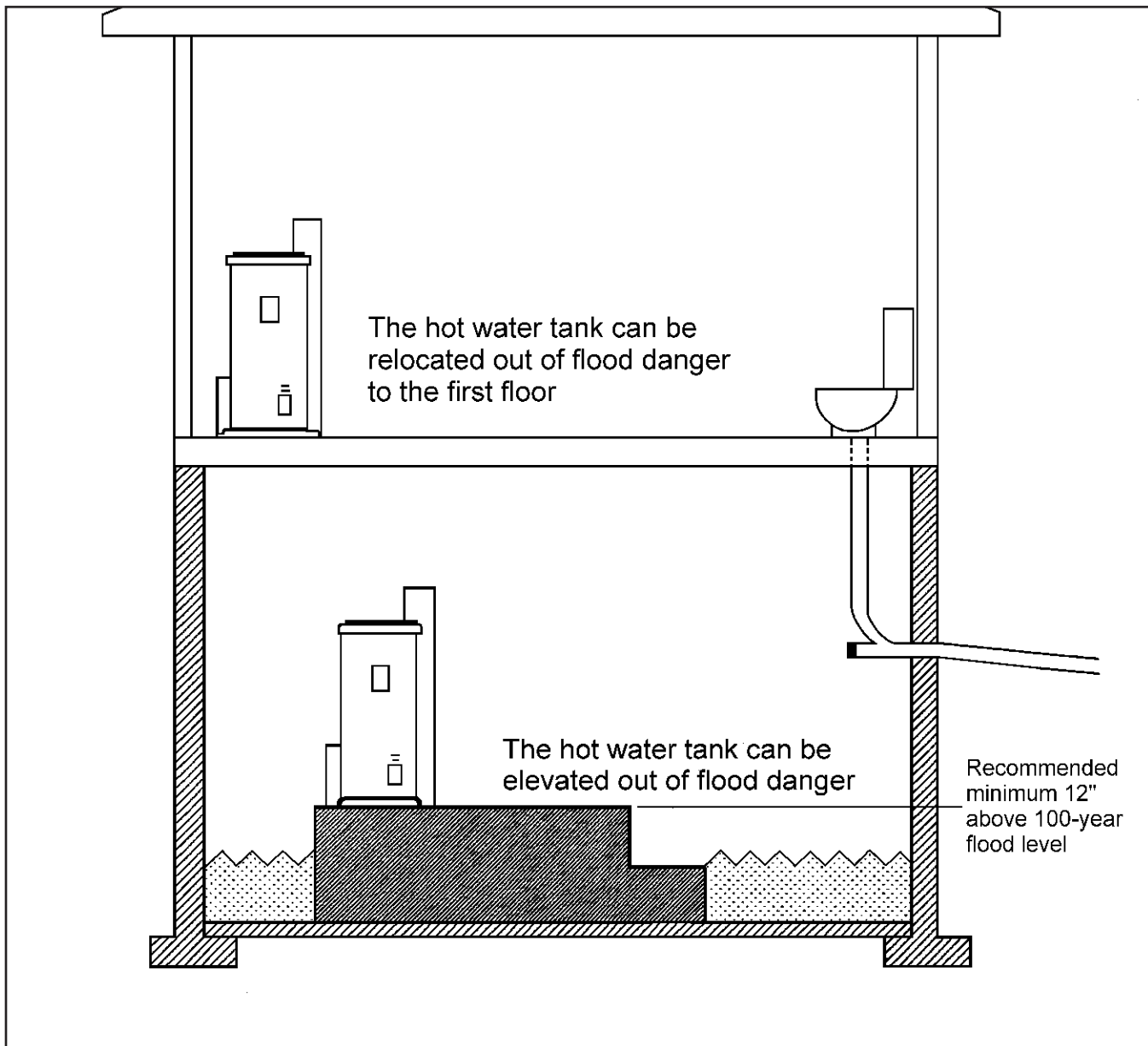

Certain repairs are not permitted for substantially damaged buildings. Check with your local building official or floodplain administrator before beginning repairs.

Elevating an Air Conditioning Compressor or Heat Pump

To protect an air conditioning compressor or heat pump elevate it at least 12" above the 100-year flood level on masonry, concrete or pressure-treated lumber base.

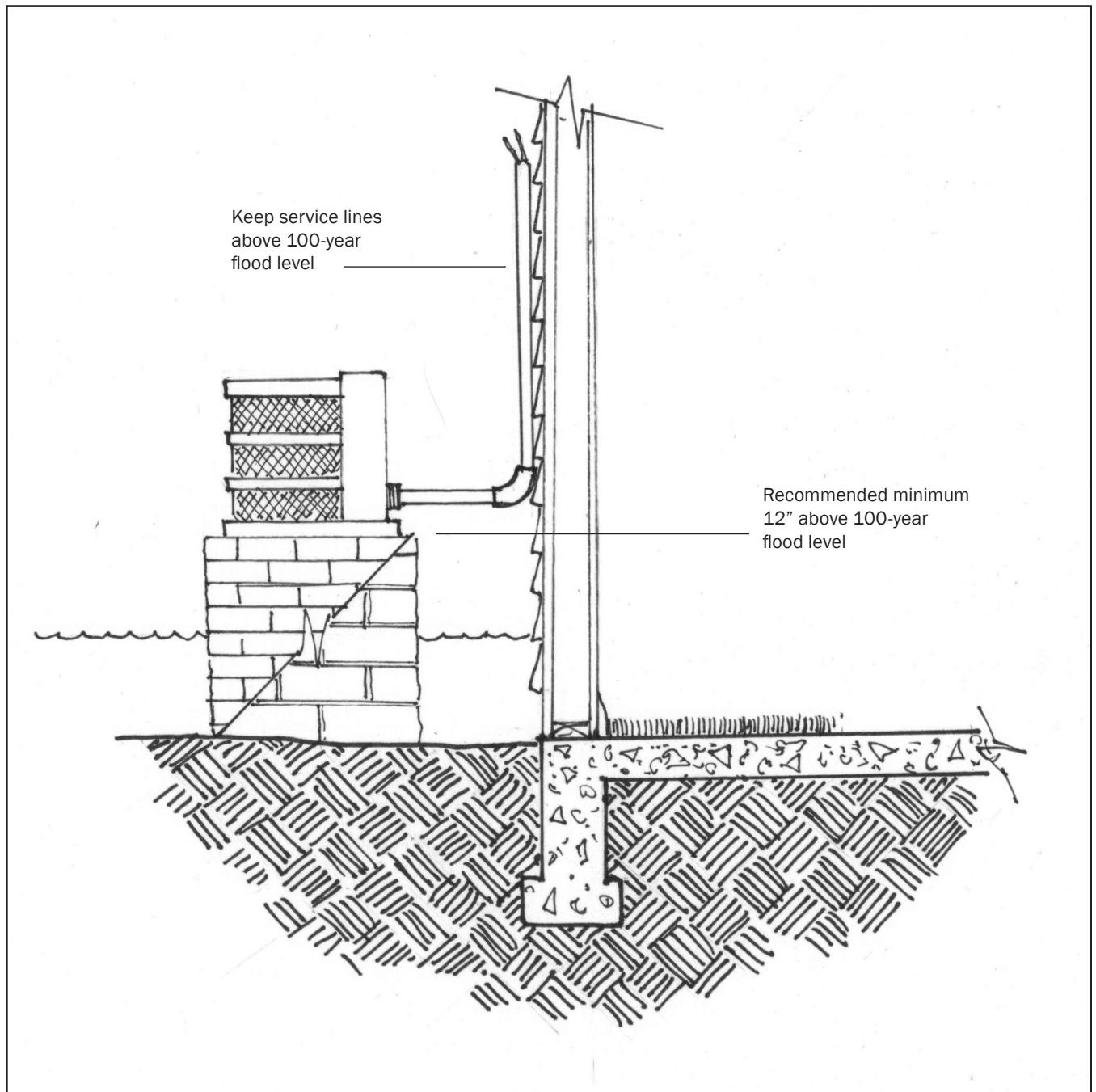

Certain repairs are not permitted for substantially damaged buildings. Check with your local building official or floodplain administrator before beginning repairs.

Anchoring a Fuel Tank

Unanchored fuel tanks can tip over or float. Escaping fuel may result in spills and fires. To prevent this, anchor your fuel tank. Use non-corrosive metal structural supports and fasteners. The type of anchorage, including slab dimensions, will vary depending on the size of the tank. Keep the fuel tank topped off to increase the tank's weight and to reduce its tendency to float.

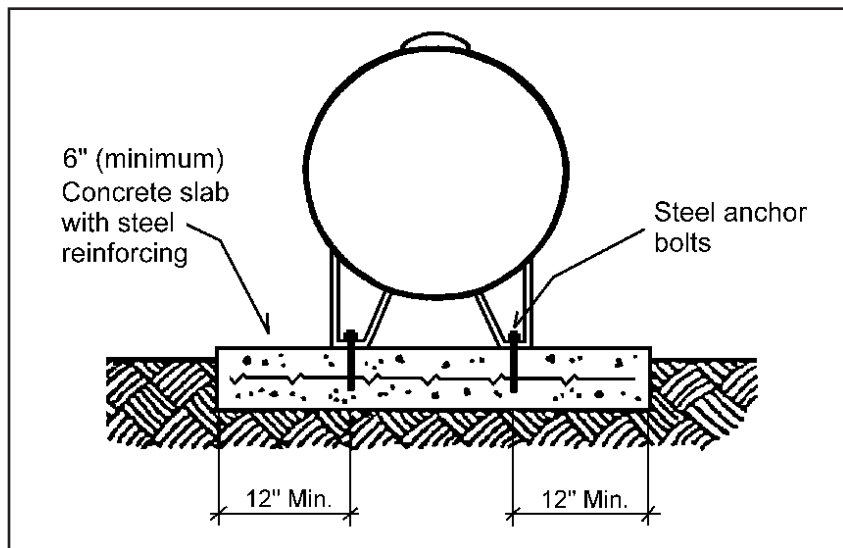

Note:

- ◆ Check with the fuel tank manufacturer for recommendations on anchoring.
- ◆ Be sure all work done conforms to state and local building codes.
- ◆ For rented tanks, check with the fuel supplier before making any modifications to the tank.

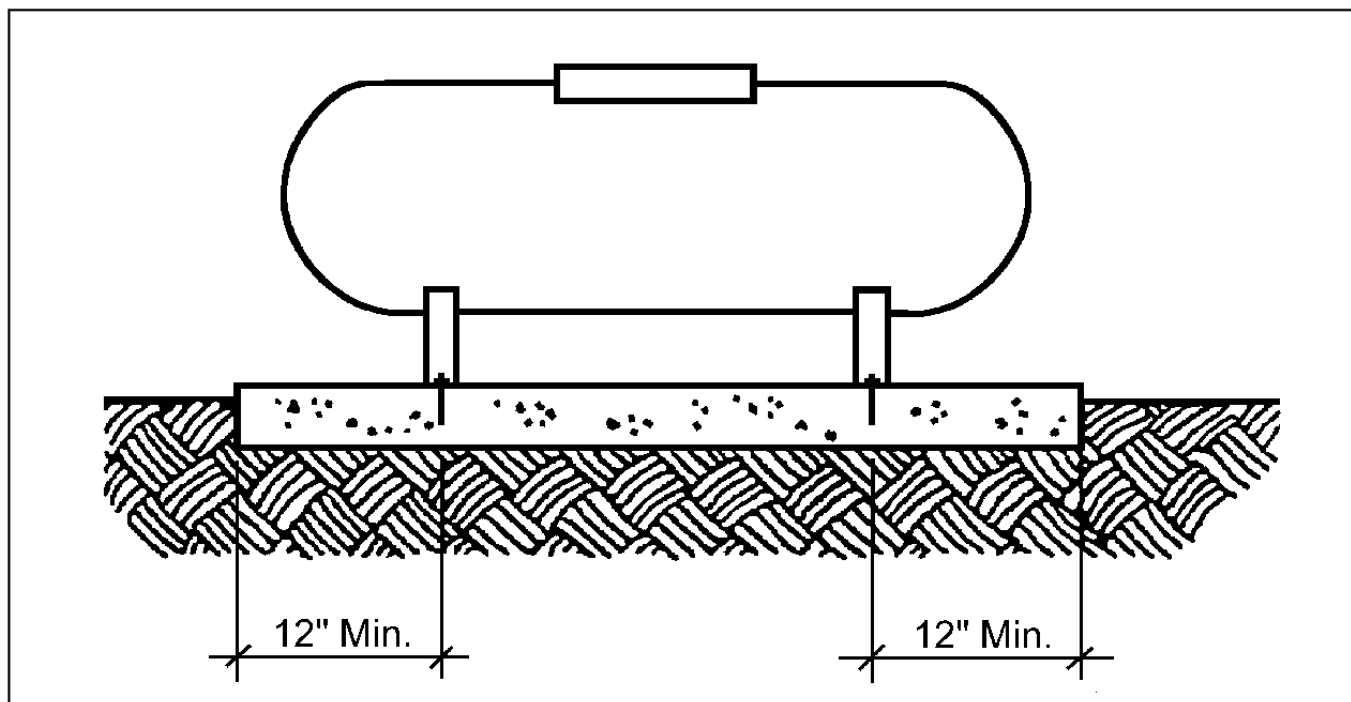

Improving Interior Wall Construction

Interior Wall Section

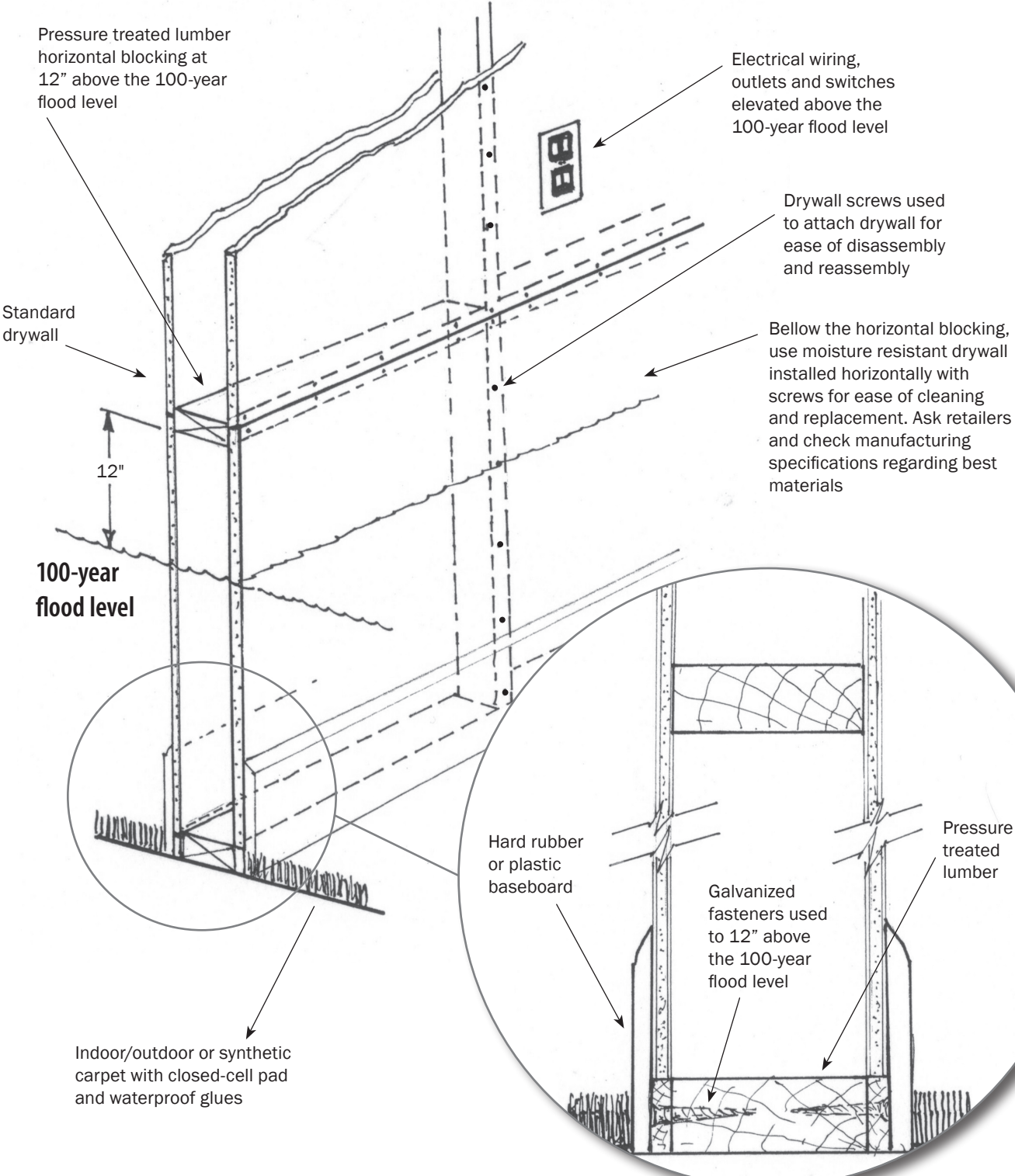

Certain repairs are not permitted for substantially damaged buildings. Check with your local building official or floodplain administrator before beginning repairs.

Pumping Out a Flooded Basement

If Your Basement Is Flooded, Don't Rush to Pump It Out

Water in the ground outside your house is pushing hard against the outside of your basement walls; and the water inside your basement is pushing right back. If you drain your basement faster than the water outside drains out of the ground, the outside pressure will be greater than the inside pressure. This unequal pressure may cause the floor to crack then buckle and the wall to crack and possibly collapse.

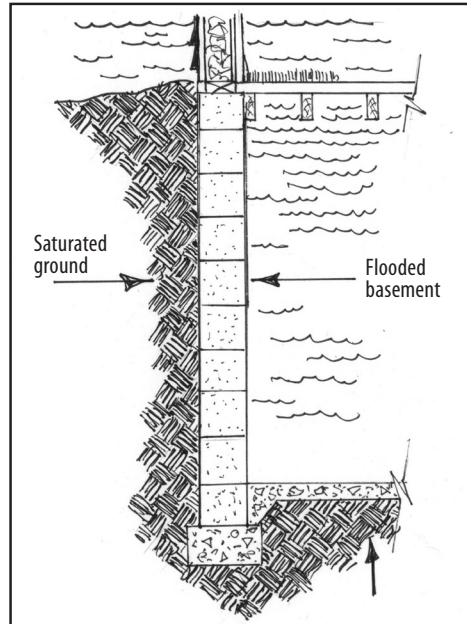

Water in the basement equalizes pressure from water outside.

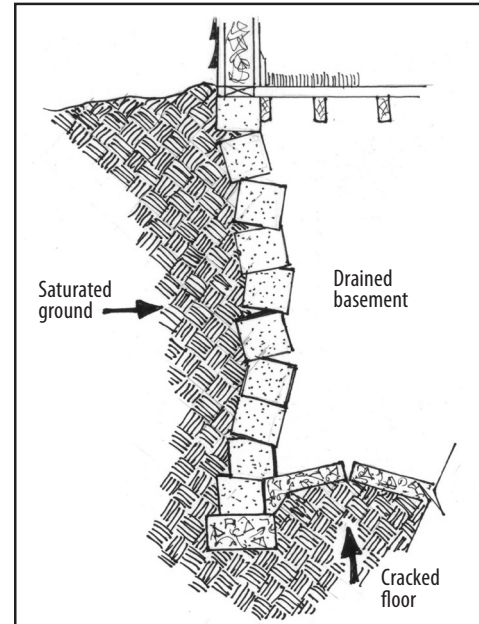

Without water in the basement, pressure from groundwater can cause the floor to crack and the walls to collapse.

How to Safely Pump Water Out of Your Basement

- ◆ Never go into a flooded basement unless you are sure the electricity is off.
- ◆ Start pumping the water out of the basement when floodwaters no longer cover the ground.
- ◆ Gasoline engines create deadly carbon monoxide exhaust fumes. Don't use gasoline-powered pumps or generators indoors.
- ◆ Pump the water level down 2 to 3 feet. Mark the level, and wait overnight.
- ◆ Check the water level the next day. If the water level went back up over your mark, it is still too early to drain your basement. Wait 24 hours, then pump the water down 2 to 3 feet again. Mark the level and check it the next day.
- ◆ When the water stops rising, pump down another 2 to 3 feet and wait overnight. Repeat steps 4 and 5 until all water is pumped out of the basement.

What to Do After Draining Your Basement

- ◆ Disinfect the floors and walls to remove bacteria left from the floodwaters.
- ◆ Before turning the power back on, check any electrical service that may have been damaged. Replace any wiring, switches, outlets that were wet during the flood.
- ◆ Remove heating and air conditioning vents or registers as soon as possible and hose out the ductwork. Flooded ducts contain mud and bacteria.
- ◆ Check your water system for loose pipes and leaks.
- ◆ Check your water supply to be certain it is not contaminated.
- ◆ Check all other utilities and drains for damage from the floodwaters.

Sump Pumps

Sump:	A hole designed to collect water.
Sump Pump:	A pump used to remove water from basements and other low areas.

A sump consists of a perforated liner set in a hole lined with coarse stone. The stone helps collect water and filter out fine particles. A filter cloth may extend the life of the sump by preventing it from silting up. Perforated water-collection pipes draining to the sump make it more effective. In some homes, all lower level waste water is pumped up and out by a sump pump.

A sump pump is usually either the submersible type with a motor and impeller under water, or the pedestal type with the impeller under water and motor on top. Both types have an automatic switch. Both types will work until the electricity is shorted by the water. With the submersible type, this happens at the end of the electrical supply wire. With the pedestal type, it happens when the water reaches the motor on top of the pedestal. Both types should have a one-way valve that will not allow the water to flow back into the discharge hose or pipe.

Caution!

Electricity and water are a hazardous combination. The sump pump must be wired into a grounded receptacle that only allows one plug. A second nearby outlet should be equipped with a ground fault circuit interrupter (GFCI). This second outlet should be handy so that people working near the sump pump will not be tempted to unplug it to use the outlet, thereby placing themselves in danger.

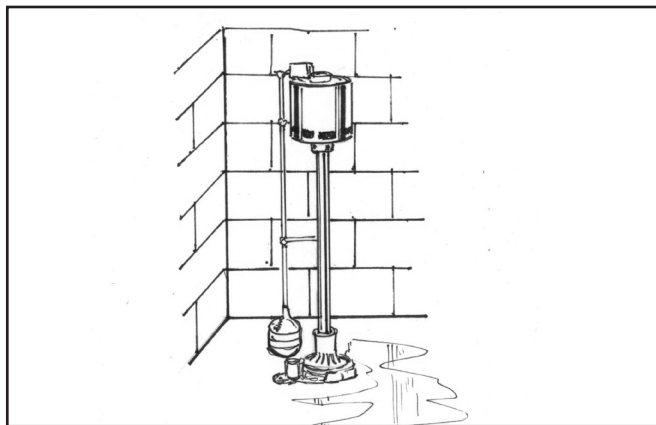

Figure 1: Pedestal Pump

If you drain your basement too quickly, the pressure outside the walls will be greater than the pressure inside the walls and that may make the walls and floor crack and collapse, causing serious damage.

To Avoid This Situation, Follow These Steps When You Pump the Water Out of Your Basement:

- ◆ Never go into a flooded basement unless you are sure the electricity is off.
- ◆ Start pumping the water out of the basement when floodwaters no longer cover the ground.
- ◆ Gasoline engines create deadly carbon monoxide exhaust fumes. Don't use gasoline-powered pumps or generators indoors.
- ◆ Pump the water level down 2 to 3 feet. Mark the level and wait overnight. Check the water level the next day. If the water went back up (it covered your mark), it is still too early to drain your basement. Wait 24 hours. Then pump the water down 2 or 3 feet again. Check the level the next day.
- ◆ When the water stops going back up, pump down another 2 to 3 feet and wait overnight. Repeat steps 4 and 5 until all water is pumped out of the basement.

Note: Removal of water from a basement where there is flooding or high groundwater may cause the basement walls to collapse. Basements should not be pumped out until the floodwaters subside.

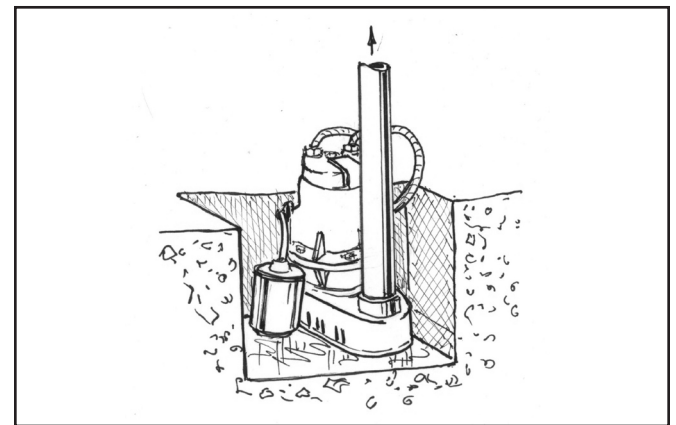
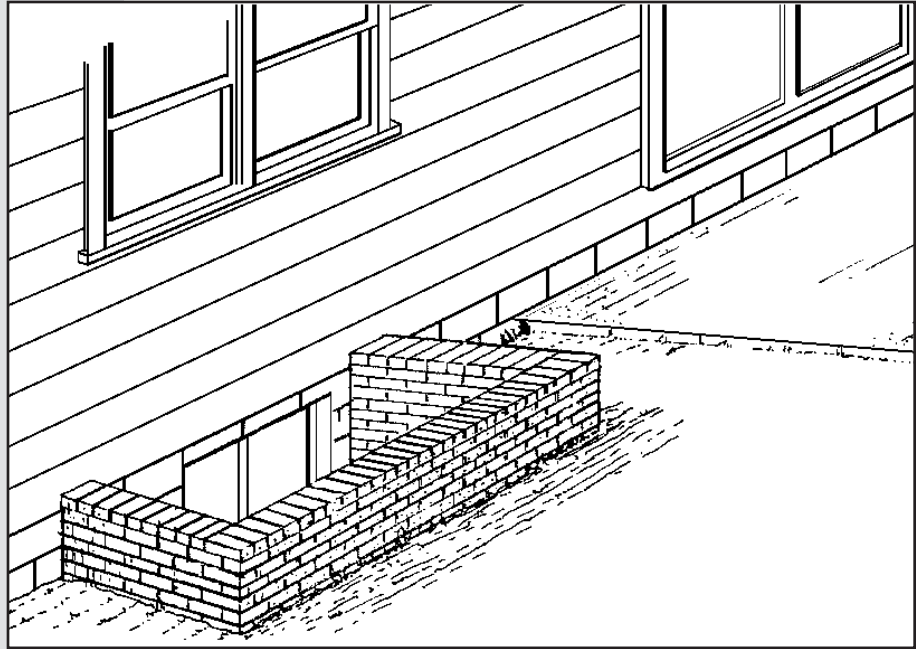

Figure 2: Submersible Pump

Installing an Exterior Floodwall

An exterior floodwall can protect a window well or stair against low level flooding. Constructed of concrete or masonry the walls should be supported by and securely tied into a footing so they will not be undercut by scouring. Understanding your particular flood situation and soil conditions is important in order to properly evaluate if a flood wall is the right solution for you. Flood walls are not effective when the ground becomes saturated.



Construct a watertight flood wall around the perimeter of the opening. The wall should not exceed three feet in height and must be constructed of steel reinforced poured concrete or steel reinforced concrete masonry units to prevent failure under flood conditions. Install a proper footing and anchor the floodwall to existing walls. Install a watertight, spring-loaded steel access door and watertight gaskets on sides and bottom of frame at any necessary opening. Be sure all work conforms to State and local building codes.

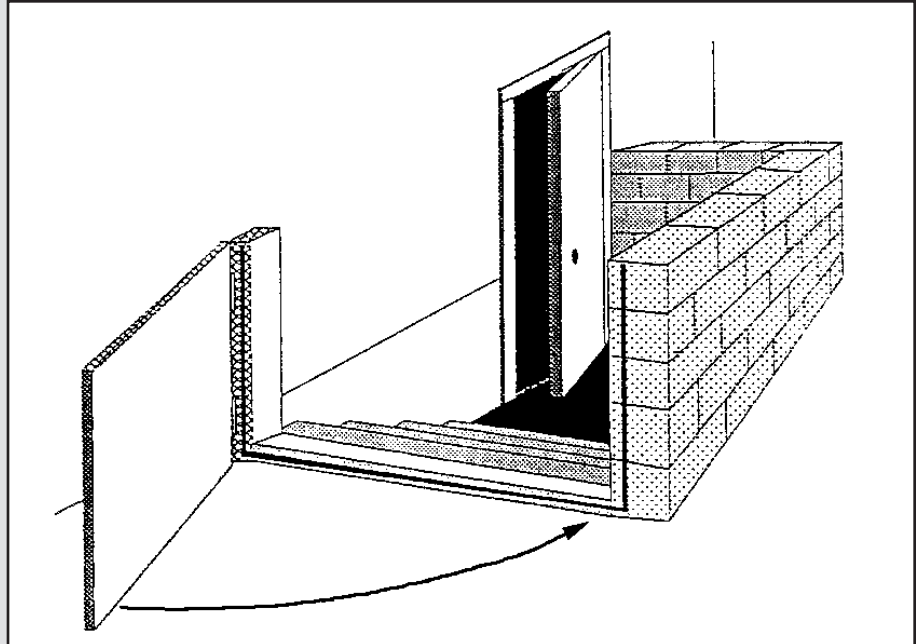

Installing an Interior Floodwall

An interior flood wall can protect against low level flooding. The wall must enclose the utilities and be at least one foot above the 100 year flood elevation. To resist the pressure of the floodwaters, construct the wall of either steel reinforced concrete blocks or steel reinforced poured concrete. Connect the new wall to the existing basement wall and floor with properly embedded reinforcing steel. For best protection, do not install gates which open into the enclosure.

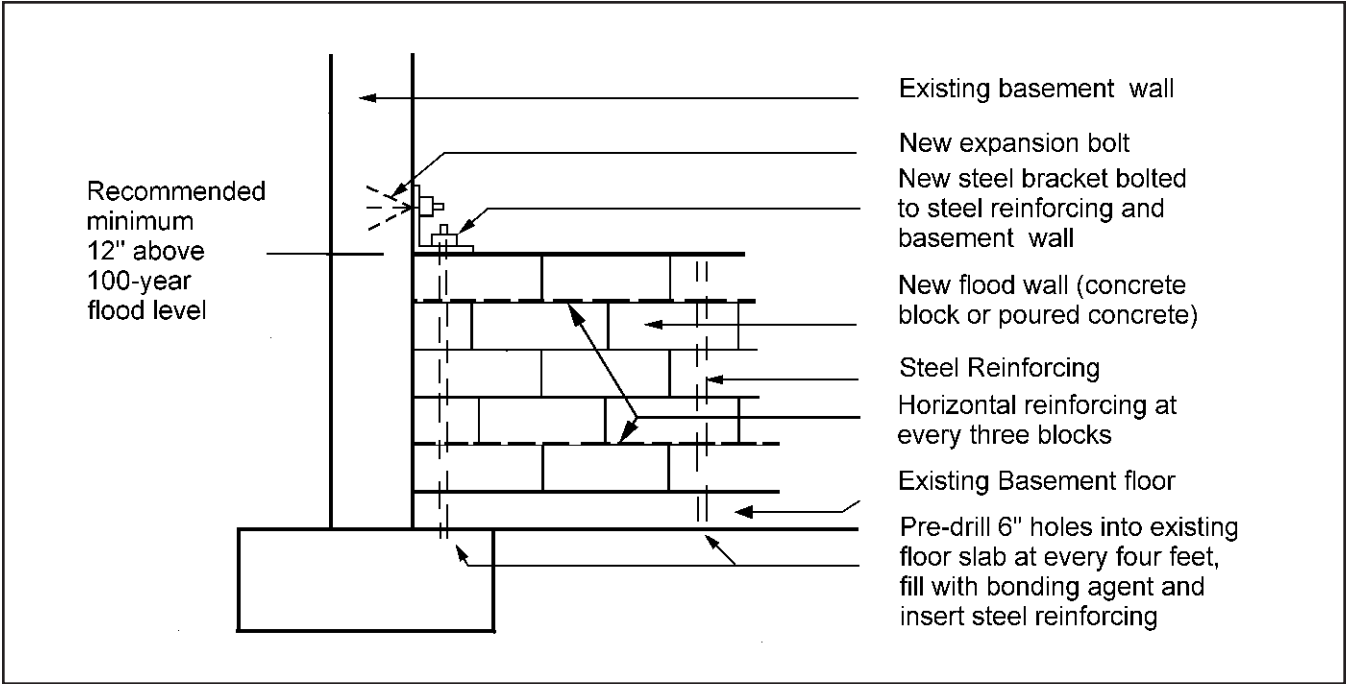
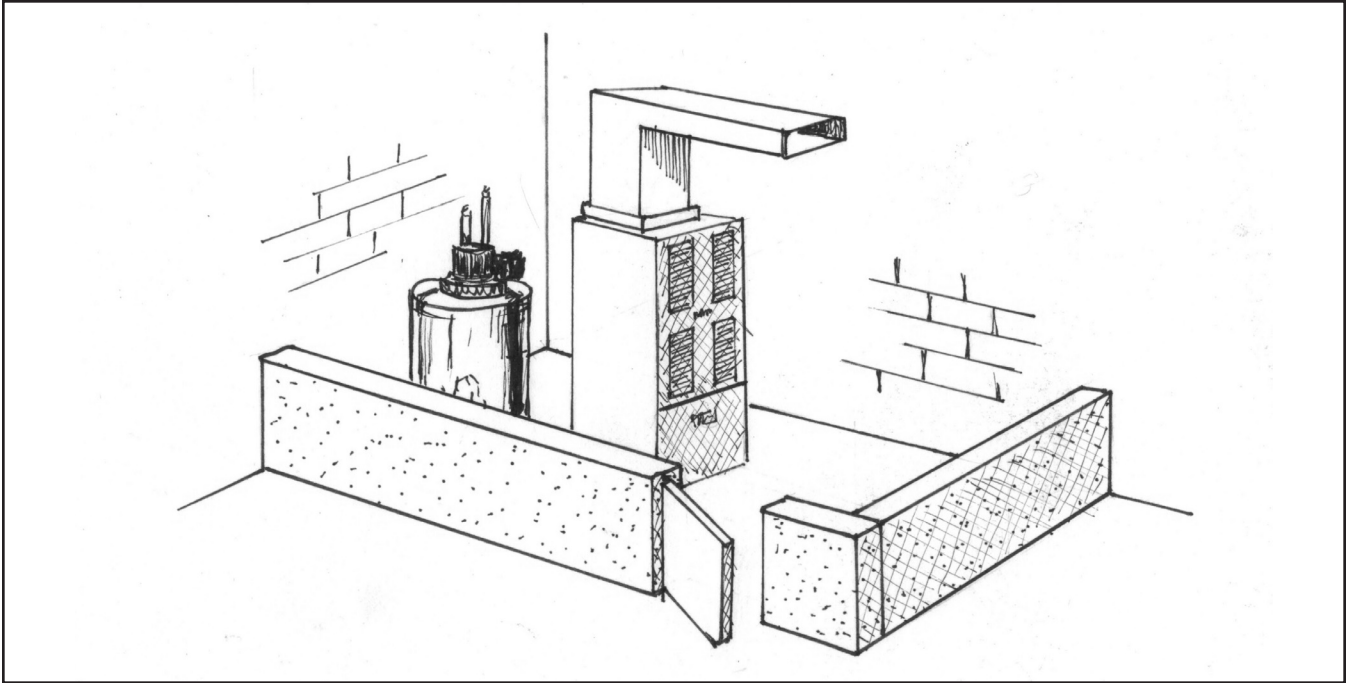

Installing an Exterior Foundation Drain System

All houses need a well-developed drain system to collect and carry away groundwaters. This means installing drains around all footings. Use perforated pipe surrounded by a filter fabric and covered with rounded drain rock to drain water that seeps through the ground. These drains should slope to a low point from which a single line should carry the water away from the house, either to a drain line in the street or to a drywell on your property. Do not drain water toward a hillside. Doing so may create concentrations of water that can trigger landslides.

A 4" deep bed of gravel under the slab should allow water to run to a central collection point where there is a sump pump with a continuous power source. If you have a lot of water under the slab, you may need to install perforated pipe drain lines to carry the water to the sump pump.

As with other retrofitting systems, a sealed house will usually need a sewer backflow protection device.

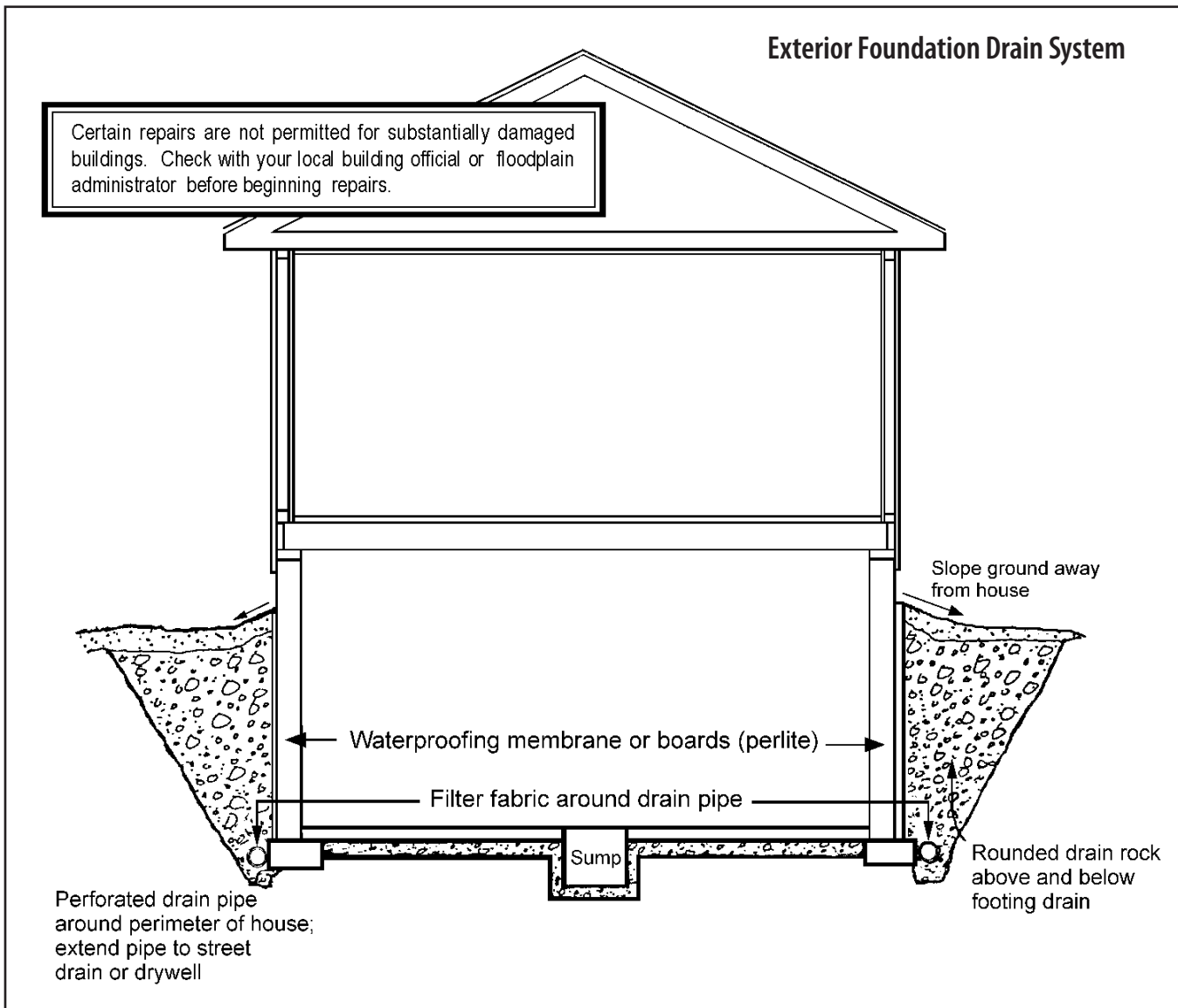

Installing an Interior Foundation Drainage System

Some homes need a basement foundation drain system to collect and carry away groundwater. This may involve cutting the floor slab, excavating a trench and installing drains along the inside perimeter of all footings. These drains should slope to a low point from which a single line can carry the water away from the house, either to a drain line in the street or a drywell on your property. Do not drain water toward a hillside. Doing so may create concentrations of water that can trigger landslides.

The basement drainage retrofit depicted below is a simple, generic system utilizing perforated drain pipe, wrapped in filter fabric, and imbedded in rounded drain rock. Other, more sophisticated systems, some of which are patented, are available to correct serious basement drainage problems. Consult an architect, engineer or licensed specialty contractor for specific information and recommendations regarding system alternatives.

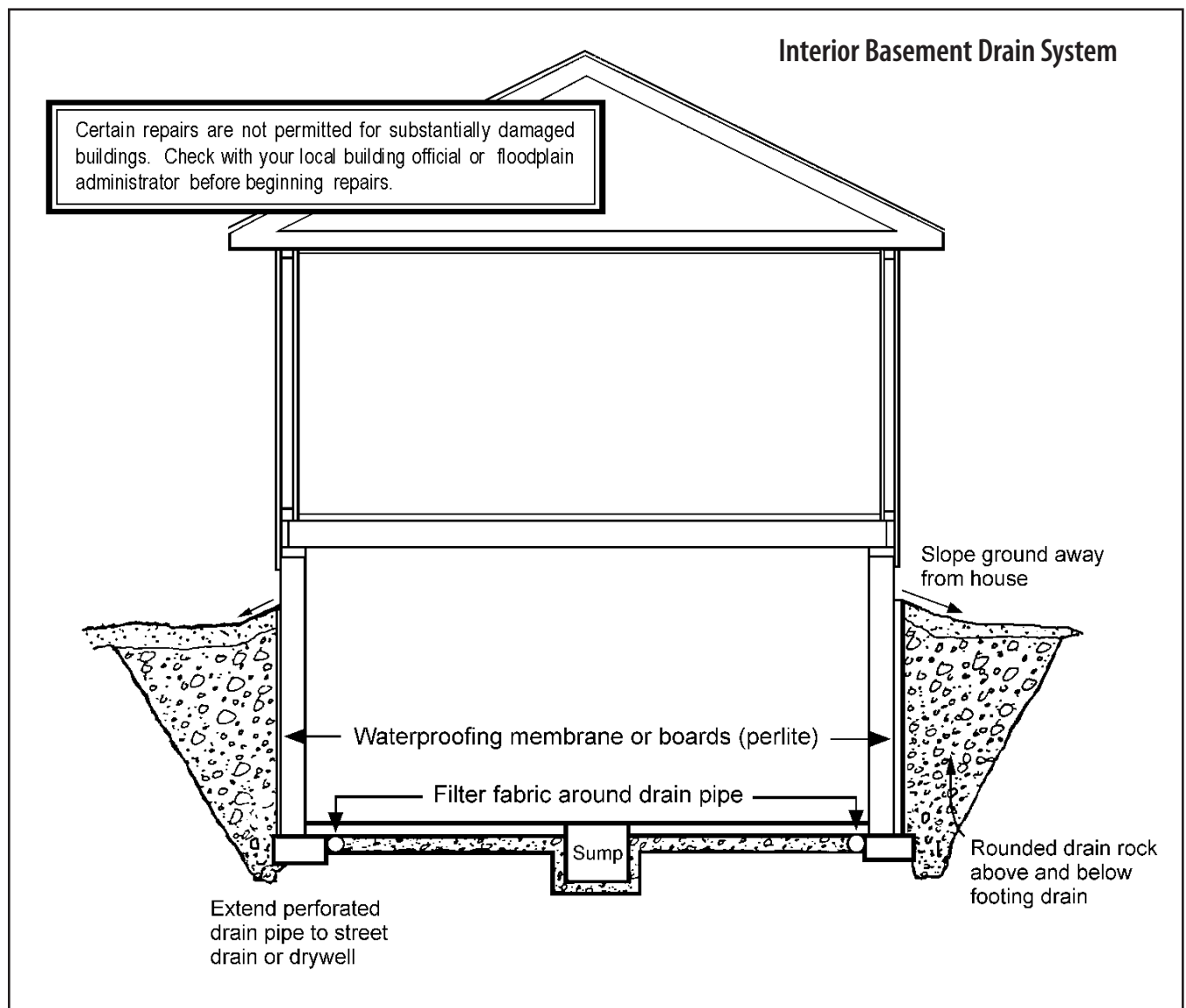

Sealing Openings in Walls

If your house is being flooded by flowing waters entering through windows, doors or other openings, you can temporarily seal those openings to keep the water out.

Make or purchase metal or wooden shields to fit the openings. Secure the shields to the openings with bolts or slide them into special positioning channels. Seal the shields to the opening with a special rubber gasket or a bead of caulking to make them water tight. Also, sandbags can be stacked in doorways or window wells and vents to make the openings water resistant.

Note: Shield height generally should not exceed 1 ½ feet above ground level. Exterior water deeper than 1 ½ feet could push the walls in if there is no water inside to push back with equal force.

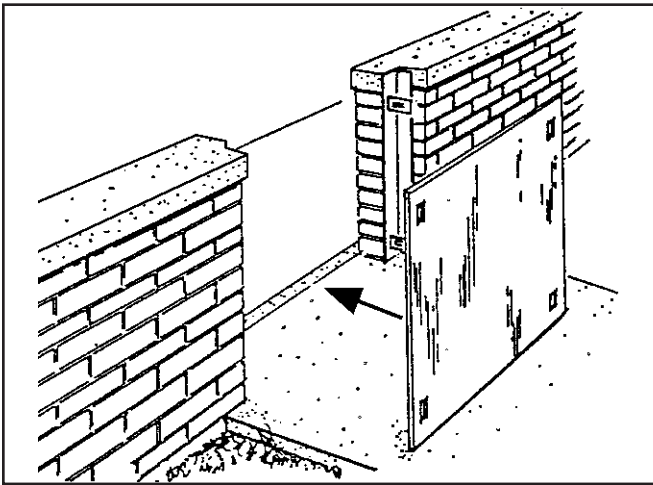

Figure 1: Bolt-on flood shield

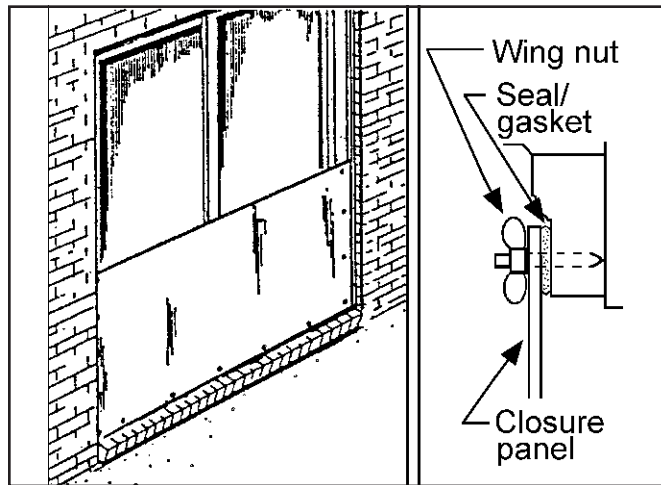
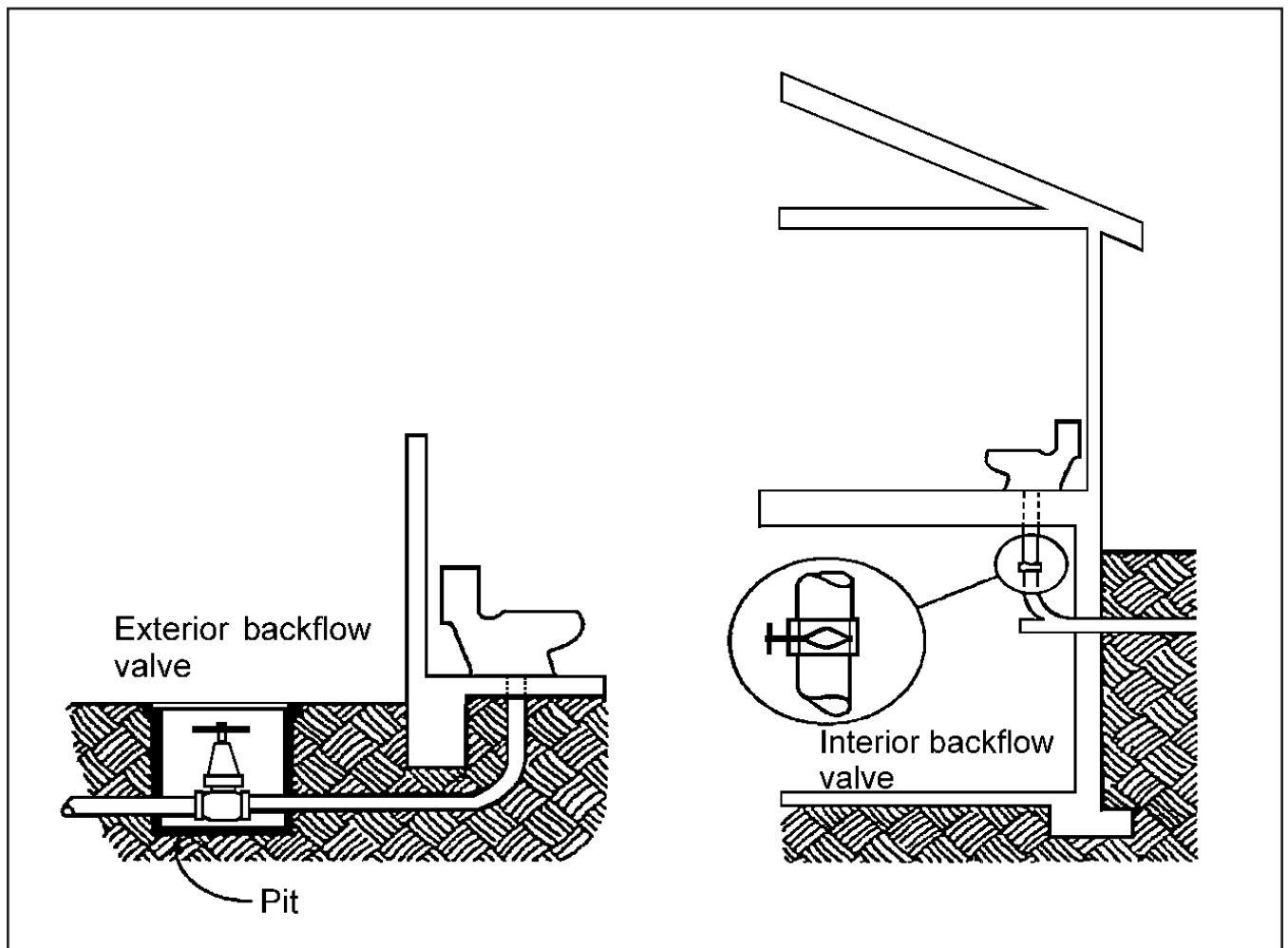

Figure 2: Removable window cover

Installing a Backflow Valve

The sewage/septic system is designed to remove sewage from a house. If flood water enters the system, the sewage can backup and enter your home. To help prevent this, install a backflow valve in the sewer line. The backflow valve is opened by the flow of sewage exiting your home, but closes when the flow reverses preventing sewage from backing up into your home. Check with your local building official for permitting and code requirements. It is recommended that this work be done by a qualified, licensed contractor.



Installing a Floor Drain Plug

The easiest way to stop sewer backup is to plug the opening where the backup can first enter the house. The sanitary system's lowest opening in the house is the floor drain. Commercial plugs are available that can be placed in the floor drain below the grate. Bolts on metal end pieces are tightened, causing a rubber gasket to expand and seal the plug in the pipe.

A plug not only stops water from entering the house but it prevents it from leaving the house as well. Because of this, it may be best to put the plug in place only during heavy rains.

You may install a plug with a float. The float allows water to drain out of the basement. When the sewer backs up, the float rises and plugs the drain. A float plug permanently installed will not interfere with the floor drain's normal operation.

Caution!

- ◆ Float plugs may be blocked open by even small amounts of debris.
- ◆ Floor drain plugs do not stop backup from coming out of the next lowest opening, for example a laundry tub or basement toilet.
- ◆ In older houses the sewer lines under the basement floor may be clay tile. A build up of water pressure can damage the sewer lines.

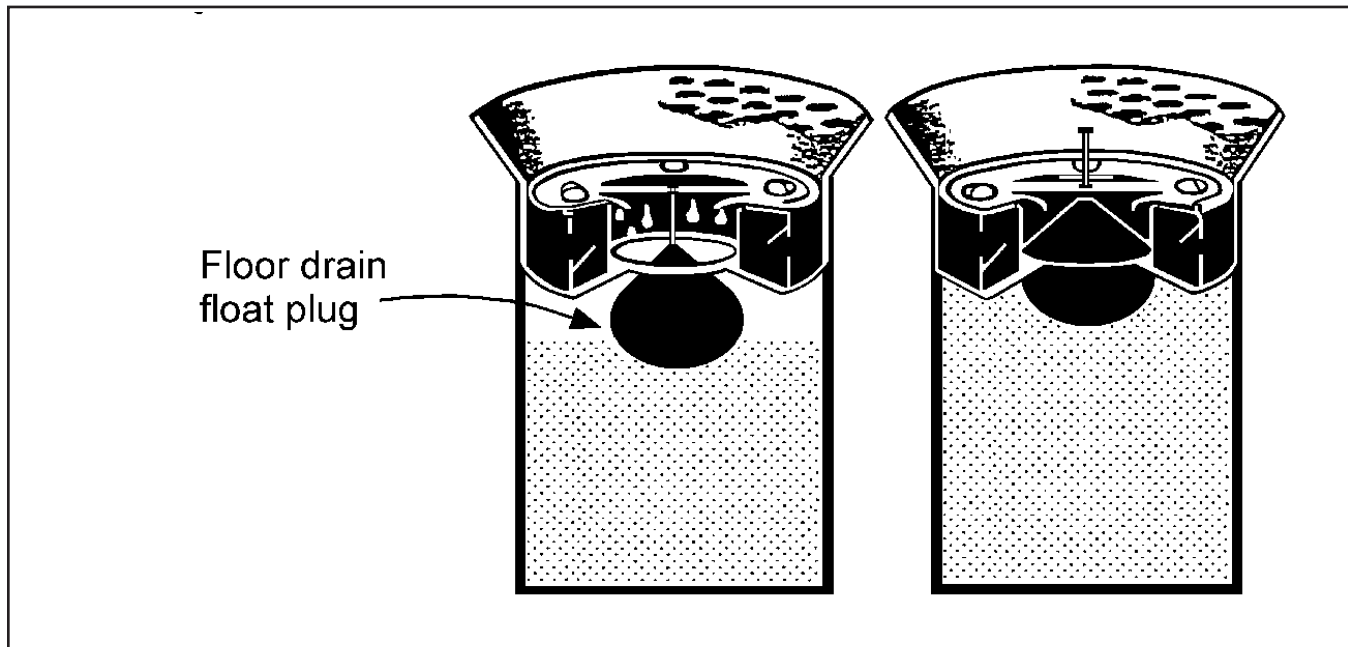

9 Landslides and Mudflows

How to Recognize Problems

Water generates & triggers most slope problems. Find where the water is coming from. Get out in the rain & check areas like hillslopes, gullies, driveway & street drainage, roof gutters & downspouts. Next, see where it flows & where it goes. Concentrated flow can cause great damage.

- ◆ **Wet, Weak And Steep** - Slope failure problems are caused by any combination of water saturation and flow; weak, heavy earth materials; and, steep slopes. Remember, WATER is the most common trigger of slope failure!
- ◆ **Steep Slopes** - Problems occur on steep slopes, especially when slope of one vertical to two horizontal is exceeded.
- ◆ **Drainage** - Channels, streams, gullying, ponding and erosion on slopes all indicate potential slope problems. Road and driveway drains, gutters, down spouts and other drainage can concentrate and accelerate flow. Ground saturation and concentrated velocity flow are a major cause of slope problems and landslide triggering.
- ◆ **Debris** - Deposition of soils and vegetation at the base of slopes show erosion, flow and creep from ground cover above.
- ◆ **Vegetation** - Condition of vegetation indicate slope conditions. Bare slopes may show erosion and sliding. Trees that bend downhill show creep of upper soils. Trees tilting uphill may show deep rotational landsliding. Patches of younger vegetation may show former slope failure. Horsetail ferns or other wet loving plants often indicate saturated ground and springs.
- ◆ **Deformed Structures** - Foundation cracks; doors and windows out of line or sticking; tilted floors; sagging decks; cracks in masonry and chimneys; cracks in driveways, curbs & roads, gaps between floors & walls, failing retaining walls & tilted power poles can be warnings of slope instability.

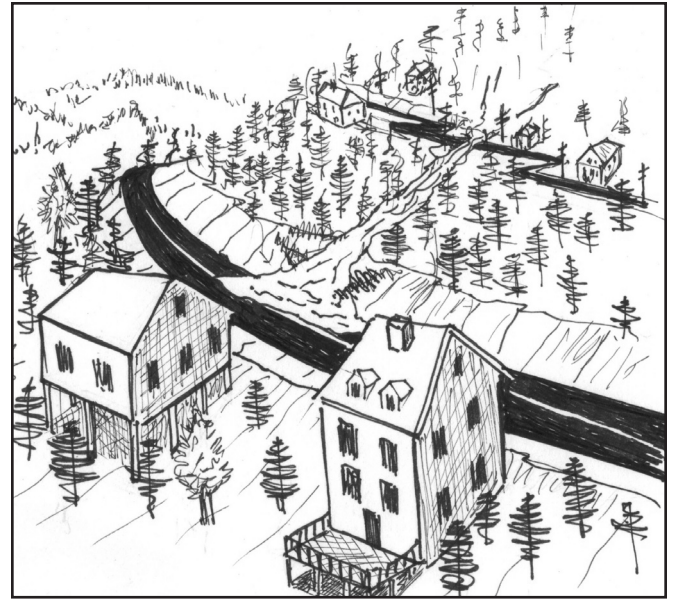

- ◆ Loose fill at the top of a slope due to yard waste, cut & fill land grading or other process can aggravate slope instability.

What You Can Do to Prevent Landslide and Slope Stability Problems:

- ◆ Divert, contain and safely discharge water around and away from unstable slopes, yards and structures.
- ◆ Use sandbags to divert water from uncontrolled spilling, such as over curbs or from gutters and downspouts, or from washing into buildings.
- ◆ Use ground cover to protect sensitive and unstable areas with plastic sheeting or tarps, burlap or other material. Wood chips and straw may be worked into the surface. Straw bales can retard velocity flow and erosion. Cover ground cracks, such as from sliding or erosion, with plastic sheeting staked or loaded down with weights. Protect cover from wind damage or other forces.

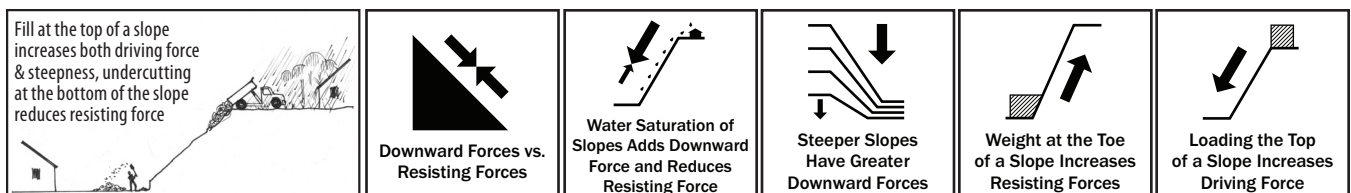

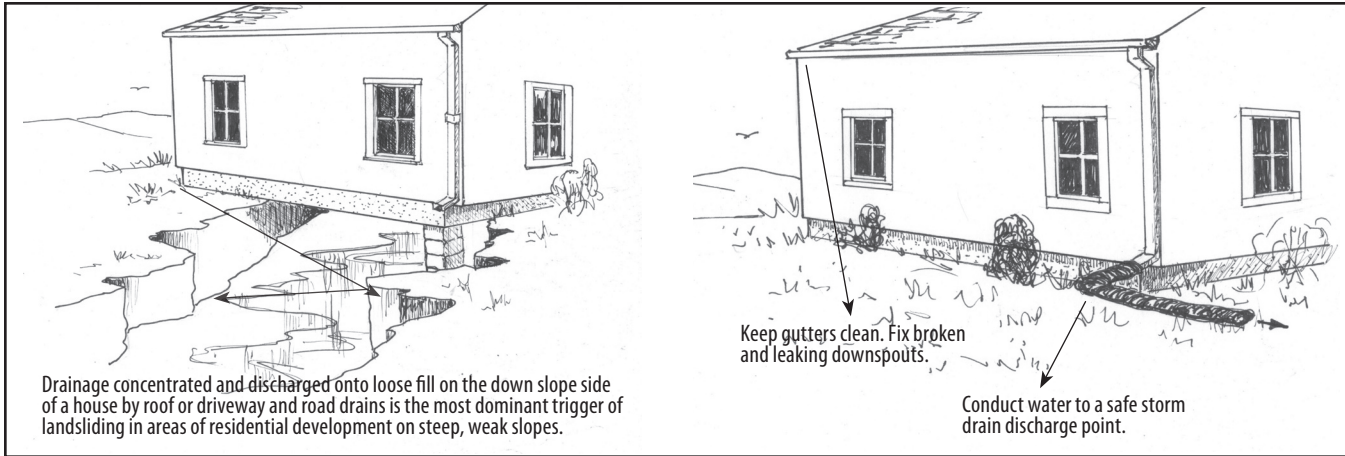

- ◆ Contain flow by directing into road gutters, storm drains or non-eroding stream beds. Flexible plastic pipe can be quickly installed. Redirect flow away from slopes and properties. Do not concentrate flow onto slopes or your neighbors property, or behind retaining walls.
- ◆ Safely discharge concentrated water to a safe, non-erodible site such as a storm drain, street gutter or rock bed of a stream. Coarse rock or bales of straw can reduce the impact of concentrated velocity flow and can reduce sediment transport.

Safety Tips

Bank Stabilization

Banks that are steep and susceptible to landslides, or are already sloughing off and encroaching upon a structure, are in need of a bank stabilization effort. Many different levels of protection are possible and it is best to consult with a geotechnical or structural engineer if you are in a hazardous area.

Vegetation

On geotechnical or slope areas where there is no threat to life or structures a vegetation planting plan may be the most reasonable approach. The different types of root systems that plants have can strengthen the cohesion of soils and bind the soil structure together into a larger unit. This can add resistance to potential landslide areas. Shallow roots can stabilize the top layer of soil, while deep tap or lateral root networks can strengthen the lower base layers. Many plants are particularly useful for bank stabilization. Your local nursery will be able to recommend plants that grow well in your climate and particular soils conditions.

Interceptor Drain

Excavate trench into impermeable soil layer. Lay geotextile into trench. Place gravel into trench and extend gravel

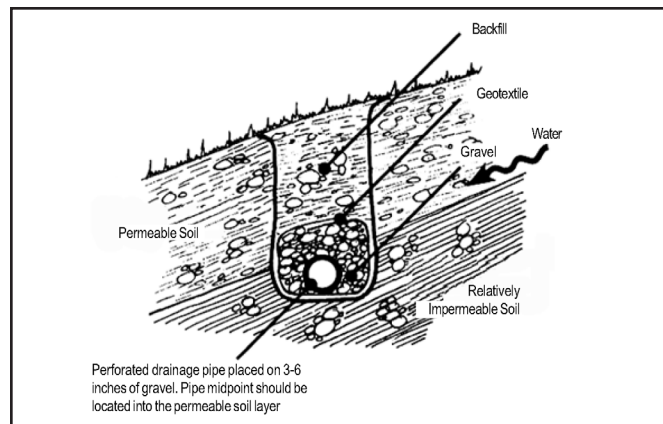

height to the maximum anticipated water level. Overlap geotextile on top of gravel. Backfill with excavated soil.

Rock Walls

Rock walls are essentially gravity walls made of stacked large rock. They primarily provide erosion protection and limited earth support. Slope, rock depth and wall height are critical to the stability of rock walls. Therefore, they should generally be limited to 15 feet or less in height and should be installed by professional rockery landscape installers. Engineers should design higher walls.

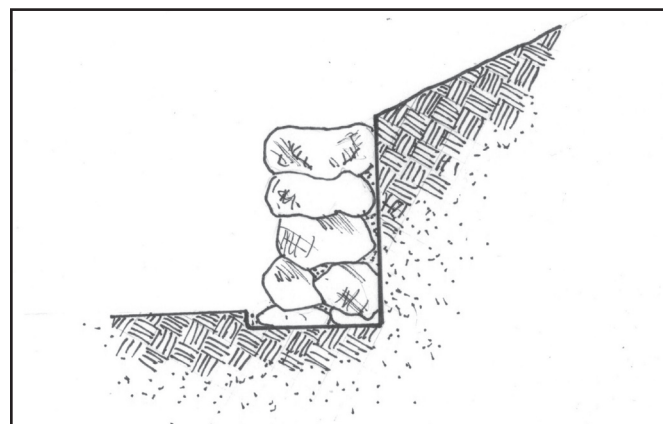

Concrete Retaining Walls

Concrete retaining walls can be constructed to withstand a large variety of structural loading conditions. They are particularly useful in steep situations where protection is needed close to the top or base of a slope. The strength of the retaining wall is highly dependent upon the strength of the materials it is made of and the manner in which they are put together. Because of the design detail required for each situation a structural or geotechnical engineer should be consulted when a concrete retaining wall is going to be used.

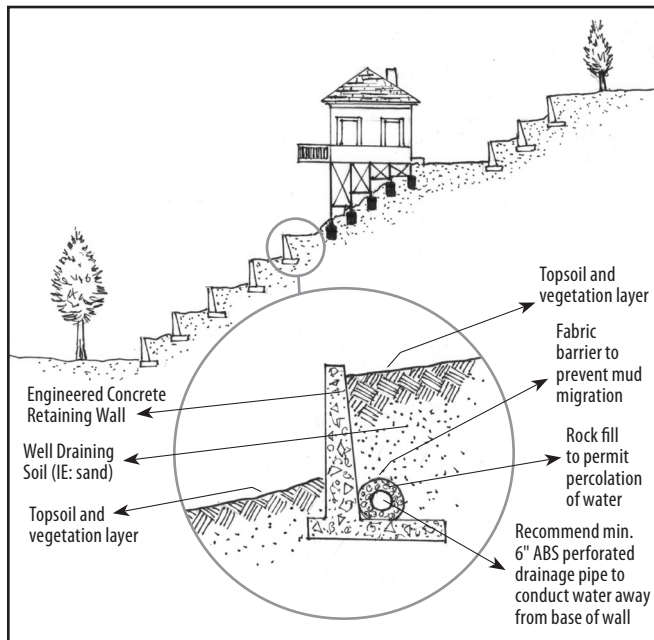

More Permanent Solutions

Major problems require major hazard mitigation and repairs. The best and easiest cure is to avoid the hazardous

sites. Urban population pressures increase the uses of marginal building sites requiring greater investment in stabilization measures. Steep, weak hillslope areas require increased code and ordinance controls to reduce risks to homeowners. Professional site investigations by both a technical engineer and an engineering geologist have been shown to reduce landslide damage over 95%. Technical solutions can greatly reduce the risks. But, private insurance or government hazard programs do not protect the homeowner at this time.

Serious problems require serious help. Hillside flooding, debris flows, erosion, and sliding often generate greater damage than the homeowner can manage on his/her own. Serious problems require specialized professional expertise of registered civil engineers with geotechnical specialist and registered engineering geologists.

Warning!

If your house is in danger of landslide damage, protect people first and **EVACUATE IMMEDIATELY!**

Danger Signs Include:

- ◆ Rapid water or slurry flow impacting house.
- ◆ In steep terrain; if flow stops or is irregular, evacuate fast! Debris-dam bursts occur very quickly.
- ◆ House cracks actively opening.
- ◆ House making noises.
- ◆ Walls or floors tilting.
- ◆ Ground cracks opening under house.
- ◆ Any portion of house falling away.

Serious problems require professional assistance. For help with major hazards, consult a licensed building



Insurance - Mudflow is covered by flood insurance policies from the National Flood Insurance Program. Flood insurance can be purchased through a local insurance agency.

10 The National Flood Insurance Program and Building in the Floodplain

What Is the National Flood Insurance Program?

The National Flood Insurance Program (NFIP) is a federal program enabling property owners and renters to purchase flood insurance. It is based on an agreement between your community and the federal government. The agreement states that if your community adopts and enforces floodplain management regulations which at least meet minimum federal requirements, the federal government will make flood insurance available in your community.

How Do I Know If I'm in the Floodplain?

The floodplain is identified as a Special Flood Hazard Areas (SFHA) in your community's Flood Insurance Study and the accompanying Flood Insurance Rate Maps (FIRMs) published by FEMA. Your community's building officials or floodplain administrators have these documents available for you to see. The flood level shown for these SFHA has a 1% chance of being equalled or exceeded in any one year. That translates into a 26% chance of flooding over a typical 30-year mortgage period as compared to a 1% chance of fire damage over the same period.

What Is Substantial Damage?

Substantial damage is damage of any origin to a structure where the cost of restoring the structure to its before damage condition would equal or exceed fifty percent (50%) percent of its pre-disaster value.

When Does It Affect Me?

The NFIP requires participating communities to regulate through building permits any new or substantially improved structures during non-disaster periods and to monitor and identify any substantially damaged structures as a result of a disaster within the community's floodplain areas. Participating communities adopt an ordinance requiring new buildings to be elevated at or above the Base Flood Elevation (BFE) within the identified floodplain. Non-residential buildings have the option of being dry flood proofed. Existing buildings that are substantially damaged or improved (50% or more) must be elevated or floodproofed to meet the same building code standard as a new building. When you apply for a building permit, you will be informed whether or not you are in a floodplain and what further steps are required to repair or reconstruct your building if you are within this defined area. If your building was flooded but not substantially damaged



there is a wide range of inexpensive measures described in this booklet that can help you reduce future flood damage.

How High Will I Have to Elevate? Or Floodproof?

The elevation or floodproofing requirement is based upon the BFE as indicated in the Flood Insurance Study of your community. This elevation may or may not be comparable to the last major flood. Though you had ten feet of water in your home during the last flood that may not mean you will need to elevate or floodproof to that height. Your community's building official can assist you in determining the elevation requirement for your structure.

What Happens If I Refuse to Comply?

Participating communities in the NFIP, agree to enforce its floodplain regulations. If you do not obtain a permit and do not elevate or floodproof when required, your community could take legal action against you. This may include stopping the development, revoking the permit, imposing a fine, or withholding a certificate of occupancy. If the structure is in violation of the regulations, flood insurance premiums could be extremely costly, possibly making the structure difficult to sell. Non-compliance could jeopardize your community's continued participation in

the NFIP. Federally secured loans and federal disaster assistance are restricted in communities not participating in the NFIP that contain one or more SFHA which have been identified on a FIRM or Flood Hazard Boundary Map (FHBM) for at least one year prior to the disaster declaration. Additionally, structures located in the floodplain which are not elevated or floodproofed as required pose a threat to the health and safety of the occupants.

What If I Have More Questions?

Your building and floodplain management officials are responsible for implementing the requirements of the local floodplain management ordinance, including the substantial damage provisions. Following a disaster declaration, the requirements pertaining to substantial damage will be presented to your community officials in detail at meetings held in various locations in the state. FEMA will work with building officials to help identify structures which may qualify as substantially damaged. In addition, FEMA will provide technical assistance to local building officials concerning the repair or reconstruction of substantially damaged structures.



FLOODSMART.GOV
An official site of the National Flood Insurance Program

11 Flood Insurance: A Good Investment

Flood Insurance is a good investment for property owners and renters. A Flood Insurance Policy:

- ◆ Covers almost all flooding conditions.
- ◆ Cannot be denied because of a structure's location in a floodplain or its flood history. Will provide up to \$500 to cover the cost of moving your possessions to higher ground - including moving a mobile home.
- ◆ Will cover replacement costs for primary single-family residences with full coverage.
- ◆ Will cover both structures and contents, if insured for both.
- ◆ Can pay a claim or partial claim within days of the disaster even without a Presidential Disaster Declaration.
- ◆ Premium can be reduced if appropriate mitigation measures are taken.
- ◆ Will pay to repair the flood-damaged part of your building or contents in accordance with your policy terms and conditions.
- ◆ Has a deductible, very much like other insurance policies.
- ◆ On policies effective June 1, 1997 and later, and under specific conditions, will pay for additional costs for retrofitting to meet LOCAL codes.

Flood Insurance is available only to residents of communities participating in the National Flood Insurance Program (NFIP). For general information about flood insurance and to learn if your community is participating in the NFIP, call 1-800-427-4661.

If items such as your furnace, water heater, electrical fuse box, or other key elements were damaged consider using the mitigation techniques in this book to reduce future flood damage. If undertaken at the time you are repairing damage, or making some other major renovation to your home, these retrofitting measures do not greatly increase the cost of repairs.

If there is a Presidential Declaration, other sources of funds may be available for mitigation. You may be eligible for a Minimal Home Repair grant, a Small Business Administration disaster loan, or Individual and Family Grant Program assistance. Ask those program officials about additional mitigation assistance to reduce future flood damage to the items they are helping to repair or replace. Information on these and many other funding sources is available at a Disaster Recovery Center (DRC). The location of the DRC in your area is available through the local news media—newspapers, radio and television—and through the Federal and State Community Relations personnel canvassing the disaster area.

Flooded? Here's What to Do:

If you experience flood damage and are covered by flood insurance, these important steps will help you when filing your flood insurance claim.

1. Save as many damaged articles as possible. If you must throw items out, take pictures to document your losses.
2. Contact your insurance agent right away. Once your insurance agent has your claim:
 - The agent will file a Notice of Loss.
 - An adjuster will be assigned to your case.
 - Once the loss has been adjusted, a Proof of Loss will be submitted, and payment can be made. Partial payment can be made to claimants upon submission of a partial Proof of Loss.